

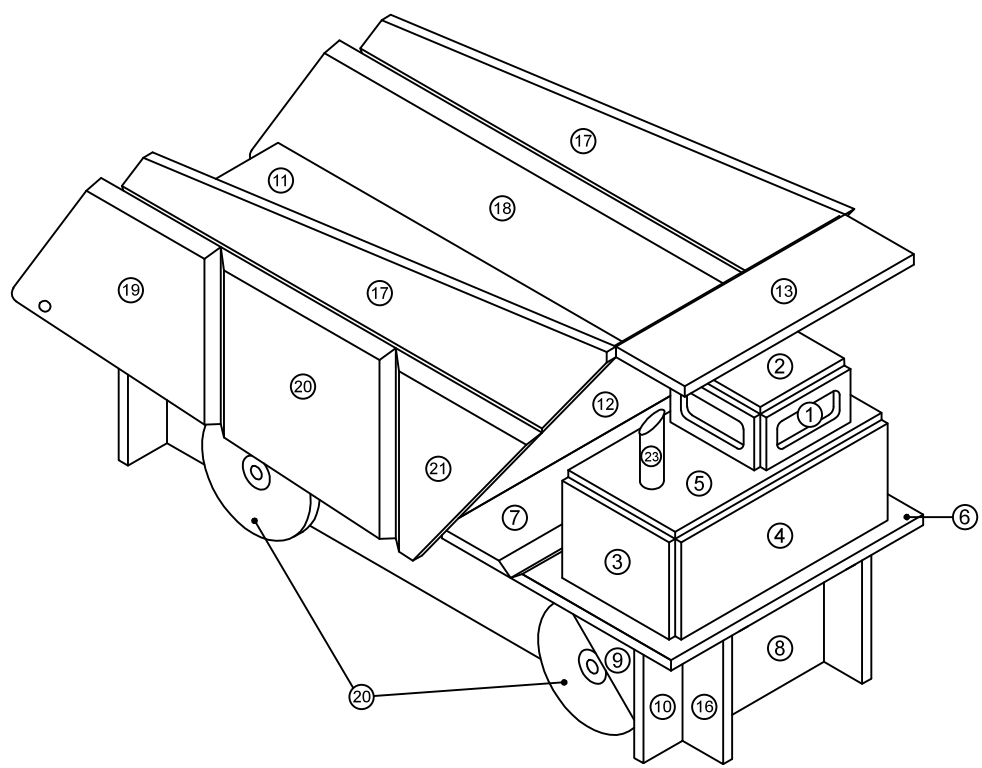

SCNC OCMT 2018  
 POST SECONDARY  
 DAY/ JOUR I  
 POSTSECONDAIRE



Project:  
TRUCK/ CAMION

Drawn By:	Date: NOV, 2017
Contact Person: DEVIN MILLIGAN	Page: 20F 2/ 2DE 2

**MATERIAL LIST**  
**LISTE DES MATÉRIAUX**

PIÈCE 1	4	30 x 55 x 3mm
PIÈCE 2	1	55 x 55 x 3mm
PIÈCE 3	2	55 x 70 x 3mm
PIÈCE 4	2	55 x 135 x 3mm
PIÈCE 5	1	70 x 135 x 3mm
PIÈCE 6	1	105 x 165 x 9mm
PIÈCE 7	1	45 x 165 x 9mm
PIÈCE 8	2	70 x 64 x 6mm
PIÈCE 9	2	40 x 40 x 6mm
PIÈCE 10	4	70 x 36 x 6mm
PIÈCE 11	1	265 x 150 x 6mm
PIÈCE 12	1	145 x 150 x 6mm
PIÈCE 13	1	45 x 150 x 6mm
PIÈCE 14	1	5 DIA X 170
PIÈCE 15	2	5 DIA X 165
PIÈCE 16	2	70 x 400 x 6mm
PIÈCE 17	1	71 x 330 x 9mm BISEAU DROIT
PIÈCE 18	1	71 x 330 x 9mm BISEAU GAUCHE
PIÈCE 19	1	92 x 307 x 9mm BISEAU GAUCHE
PIÈCE 20	1	103 x 73 x 9mm BISEAU DROIT
PIÈCE 21	1	114 x 83 x 9mm BISEAU DROIT
PIÈCE 22	1	96 x 87 x 9mm BISEAU DROIT
PIÈCE 23	4	72 DIA 12mm BISEAU DROIT
PIÈCE 24	1	TIGE de 12 mm

Project:

TRUCK / CAMION

Drawn By:

Date:

NOV, 2017

Contact Person:

Page:

DEVIN MILLIGAN

20F2/ 2DE2

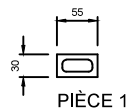

PIÈCE 1

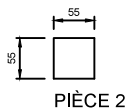

PIÈCE 2

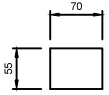

PIÈCE 3

Cabine de conduite

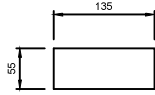

PIÈCE 4

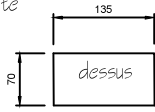

PIÈCE 5

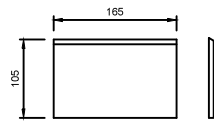

PIÈCE 6

PLAQUE DE BASE DE LA  
CABINE DE CONDUITE

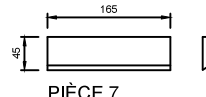

PIÈCE 7

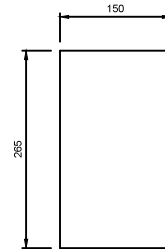

PIÈCE 11

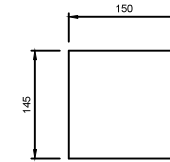

PIÈCE 12

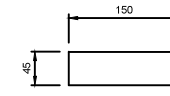

PIÈCE 13

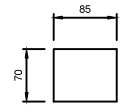

PIÈCE 8

Plaques signalétiques internes

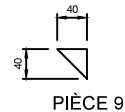

PIÈCE 9

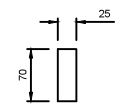

PIÈCE 10

Plaques signalétiques latérales

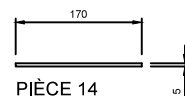

PIÈCE 14

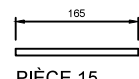

PIÈCE 15

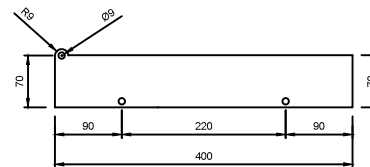

PIÈCE 16

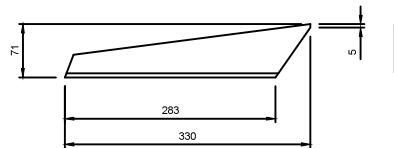

PIÈCE 17

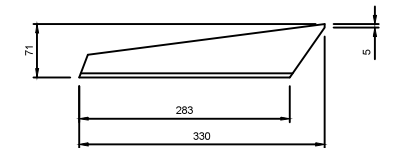

PIÈCE 18

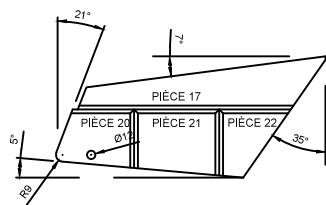

BENNE DU CAMION

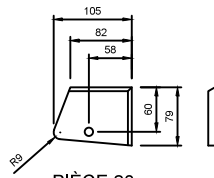

PIÈCE 20

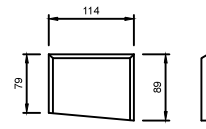

PIÈCE 21

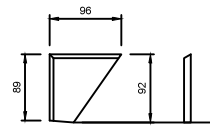

PIÈCE 22

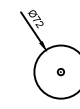

PIÈCE 23



PIÈCE 24

Cheminée d'échappement