



2018

SCNC

SKILLS CANADA
NATIONAL COMPETITION

OCMT

OLYMPIADES CANADIENNES
DES MÉTIERS ET
DES TECHNOLOGIES



skillsCompétences
Canada
Edmonton2018

TEST PROJECT / PROJET D'ÉPREUVE

INDUSTRIAL CONTROL CONTRÔLE INDUSTRIEL

POST - SECONDARY /
NIVEAUX POSTSECONDAIRE

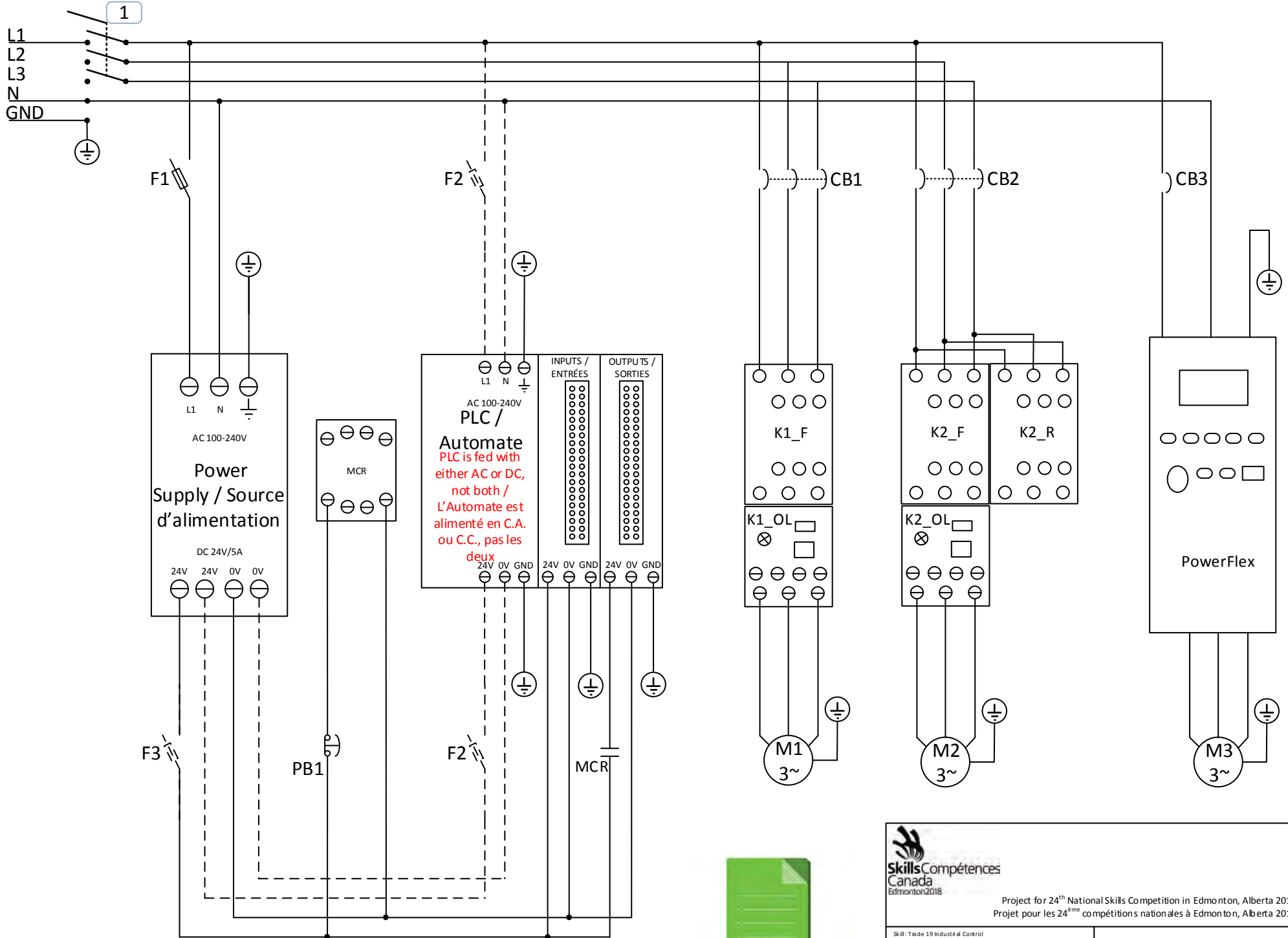



DOCUMENT USE



Project for 24th National Skills Competition in Edmonton, Alberta 2018
Projet pour les 24^{ème} compétitions nationales à Edmonton, Alberta 2018

Skill: Trade 19 Industrial Control
Compétence: Métier 19 Contrôle Industriel

Scale / Échelle: Not to Scale / Aucune

Date: June 2018 / Juin 2018

Designer / Concepteur: 2018 Trade 19 NTC / CNT métier 19 2018

Power Layout / Schémas de puissance

Rev: 4.0 (2017-Dec-08)

Page: 1 / 5

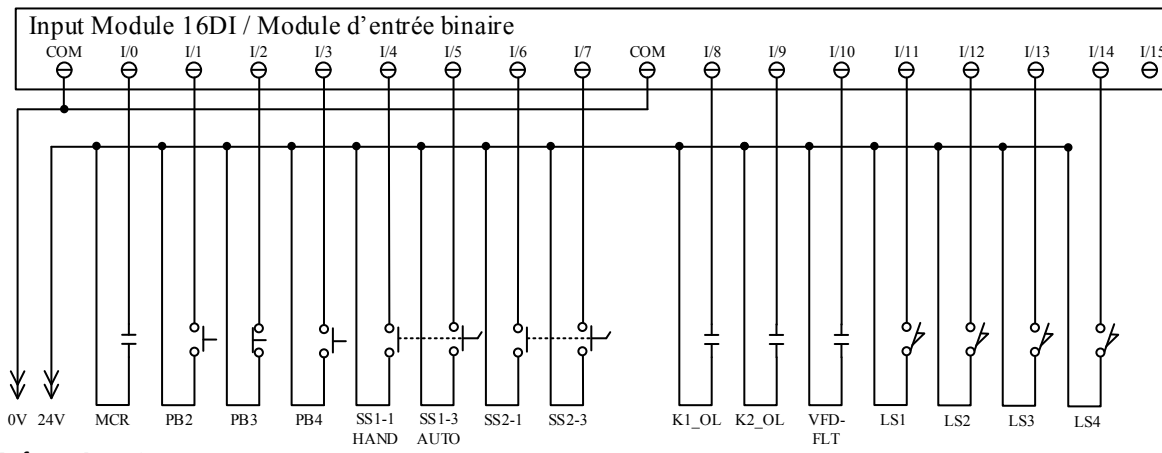

Refer to Page 1
Se référer à la page 1

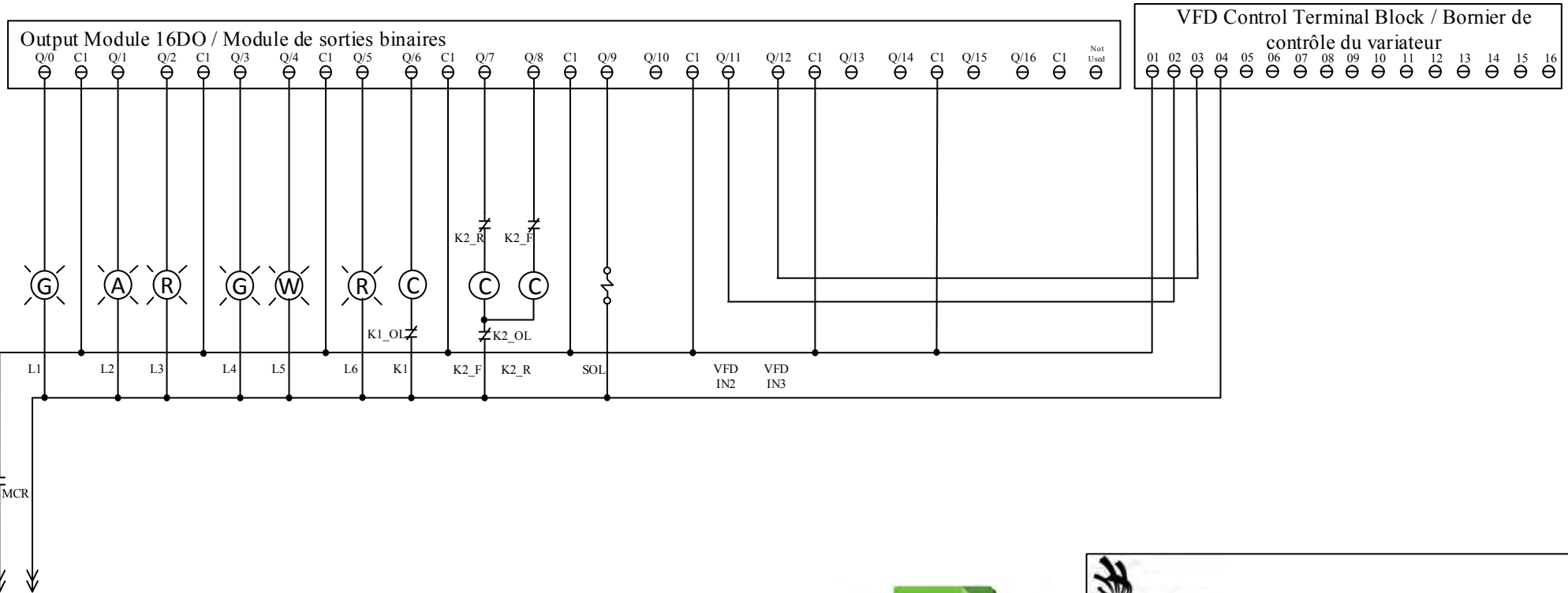

Refer to Page 1
Se référer à la page 1



DOCUMENT USE

		Project for 24 th National Skills Competition in Edmonton, Alberta 2018 Projet pour les 24 ^{ème} compétitions nationales à Edmonton, Alberta 2018	
Skill: Trade 19 Industrial Control Compétence: Métier 19 Contrôle Industriel		Control Layout / Schémas de contrôle	
Scale / Échelle : Not to Scale / Aucune			
Date: June 2018 / Juin 2018		Rev: 4.0 (2017-Dec-08)	
Designer / Concepteur: 2018 Trade 19 NTC / CNT métier 19 2018		Page: 2 / 5	

Back plate suggested layout / Disposition proposée de la plaque de montage

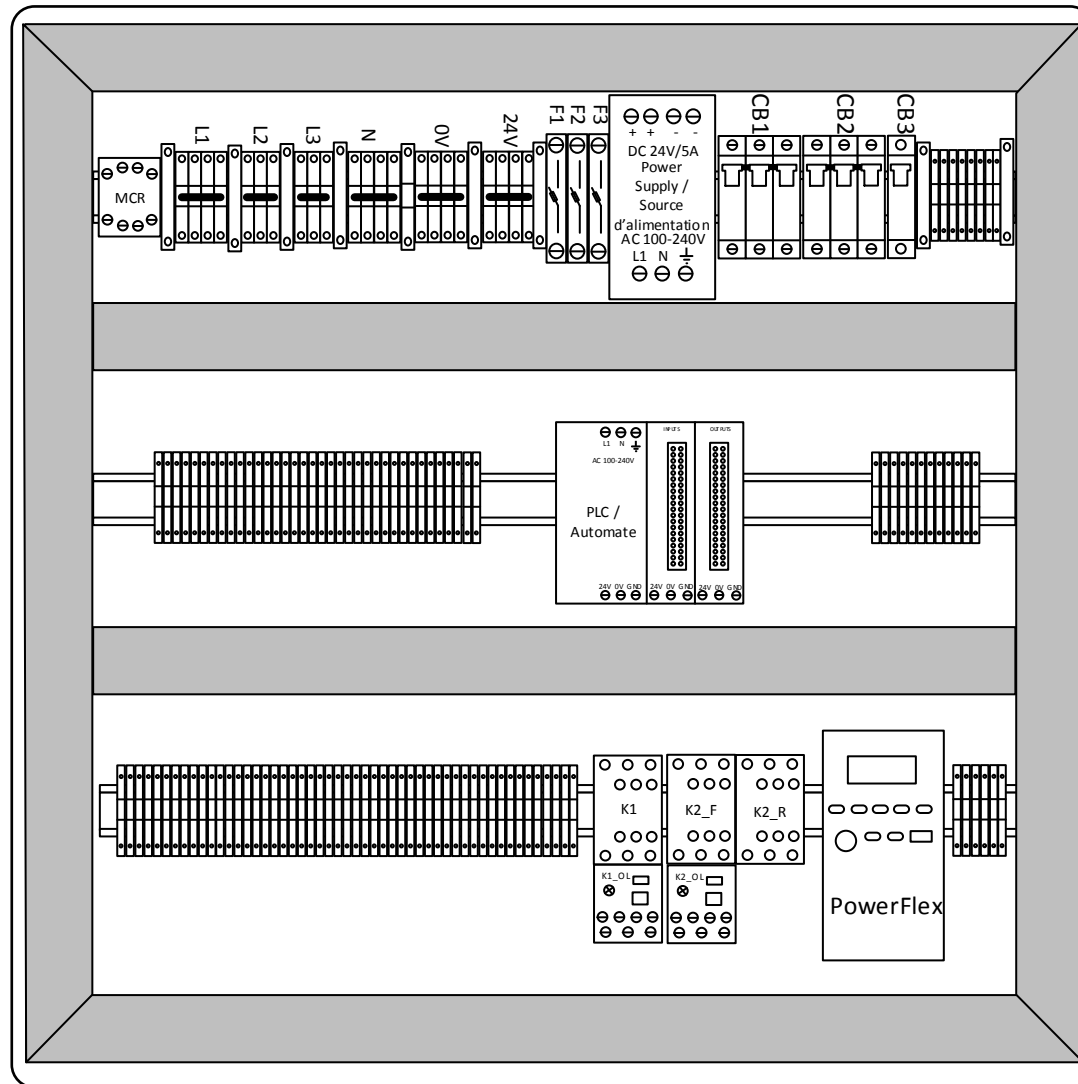

DOCUMENT USE

Left Side View / Vue du côté gauche

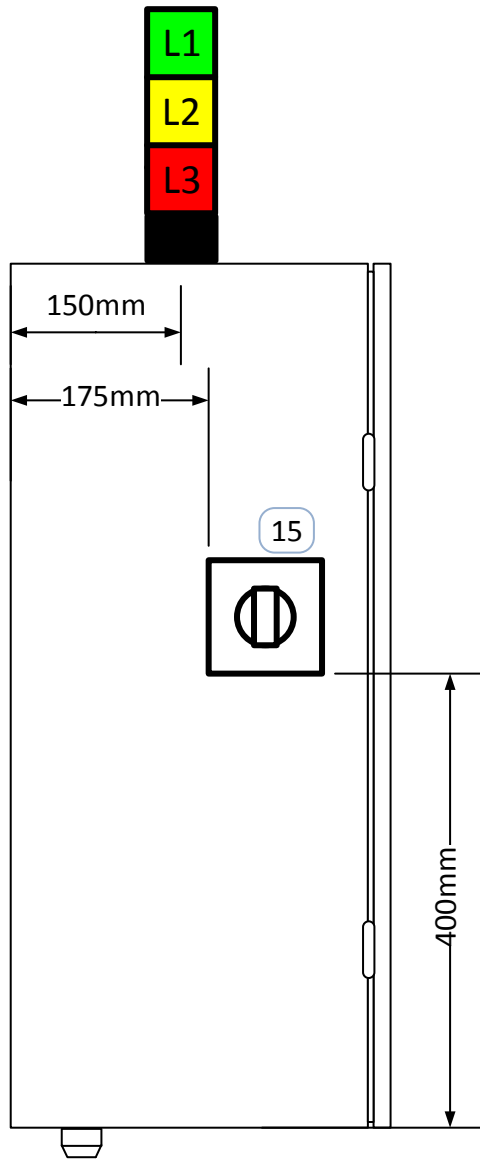

Front View / Vue de façade

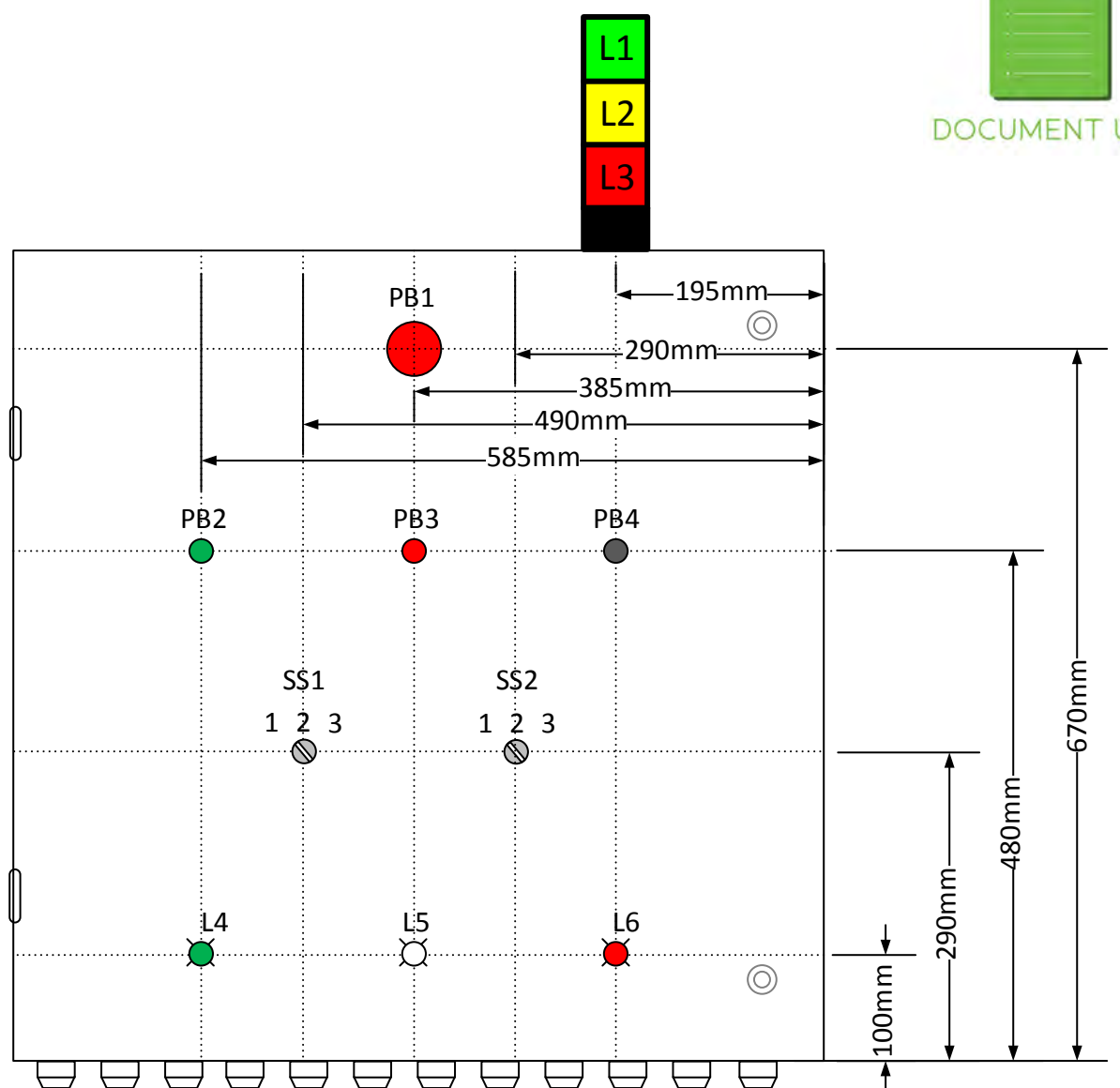

DOCUMENT USE



Project for 24th National Skills Competition in Edmonton, Alberta 2018
 Projet pour les 24^{ème} compétitions nationales à Edmonton, Alberta 2018

Skill: Trade 19 Industrial Control Compétence: Métier 19 Contrôle industriel
Scale / Échelle: Not to Scale / Aucune
Date: June 2018 / Juin 2018
Designer / Concepteur: 2018 Trade 19 NTC / CNT métier 19 2018

Door Layout / Disposition
de la porte

Rev: 4.0 (2017-Dec-08)

Page: 4 / 5

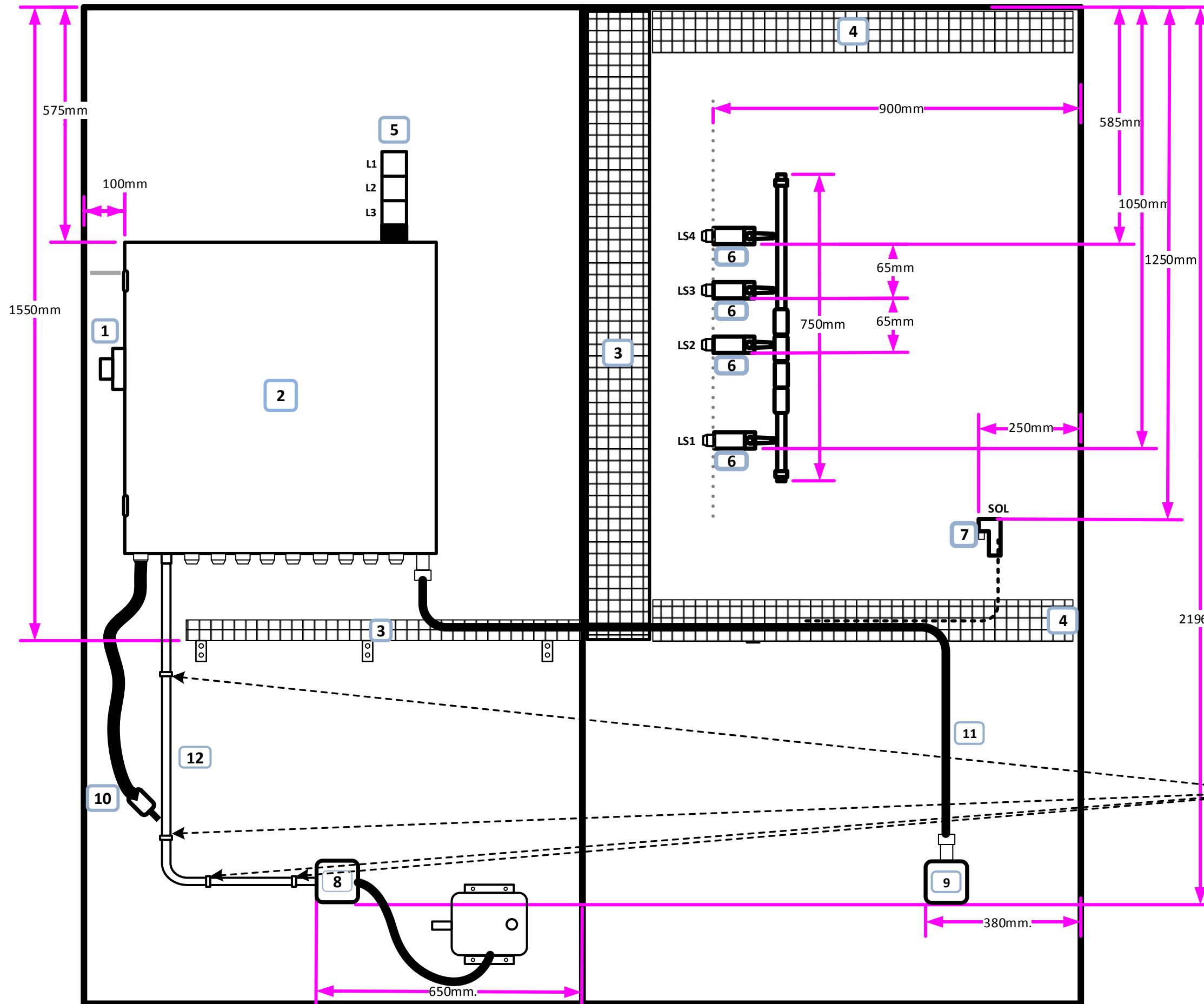

1. Panel Mounted Disconnect / Sectionneur monté en surface
2. Control Cabinet / Armoire de contrôle
3. 6" Wide Wire Basket Tray / Chemin de câble de 6po
4. 4" Wide Wire Basket Tray / Chemin de câble de 4po
5. Stack Light / Tour lumineuse
6. Limit Switch / Interrupteur de fin de course
7. Solenoid Valve / Soupape Solénoïde
8. Junction Box (M3) / Boîte de jonction (M3)
9. Junction Box (M1) / Boîte de jonction (M1)
10. 120V Cheater cord / Cordon d'alimentation 120V
11. TECK90 cable / Câble TECK90
12. ½" EMT conduit / Conduit EMT ½po



DOCUMENT USE

All measurements will be taken from where it is shown on the drawing on the flat portion of device, if no dimension is given it is at installer's discretion / Les mesures doivent être prises où le dessin l'indique sur la partie plate des composants, si aucune mesure n'est indiquée elle est laissée à la discrétion de l'installateur

