

Dimensions subject to change-informational purposes only
 La dimension de 175 mm part du CENTRE DU Té jusqu'au CENTRE du Té

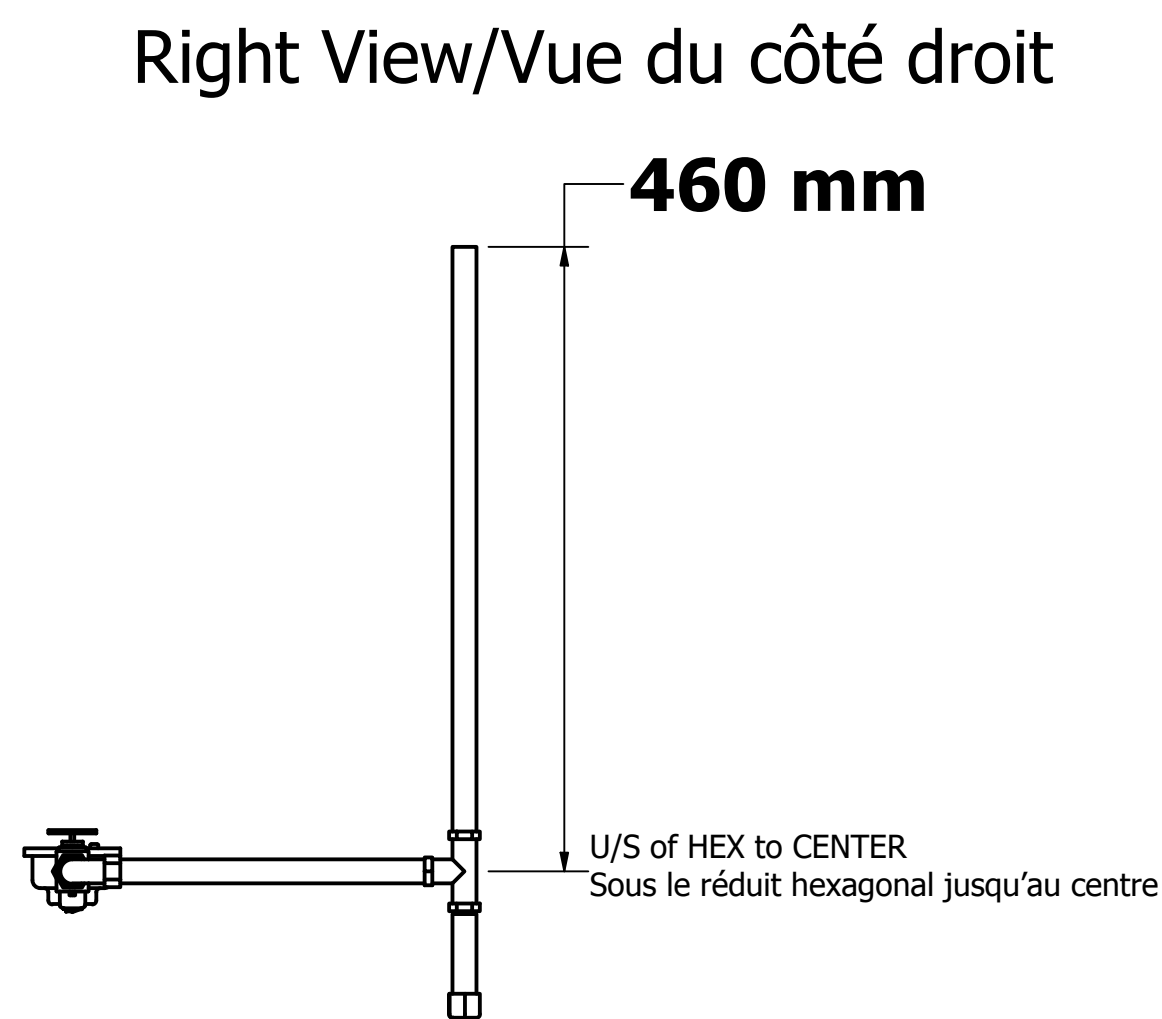
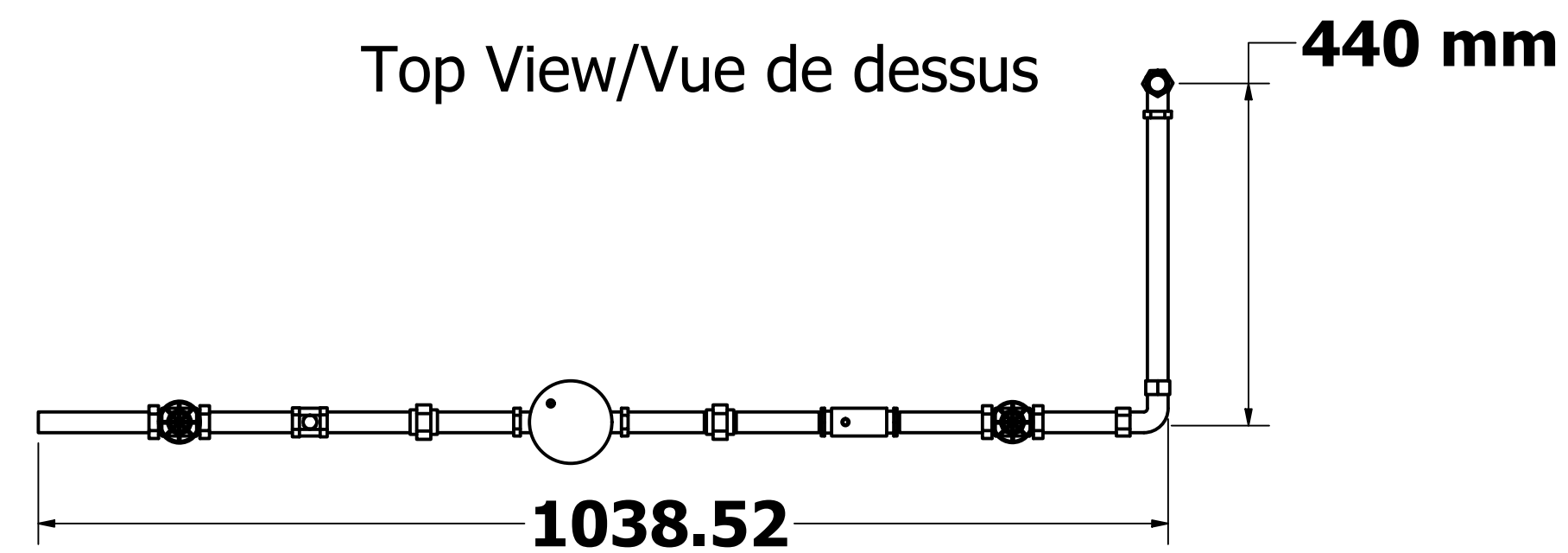
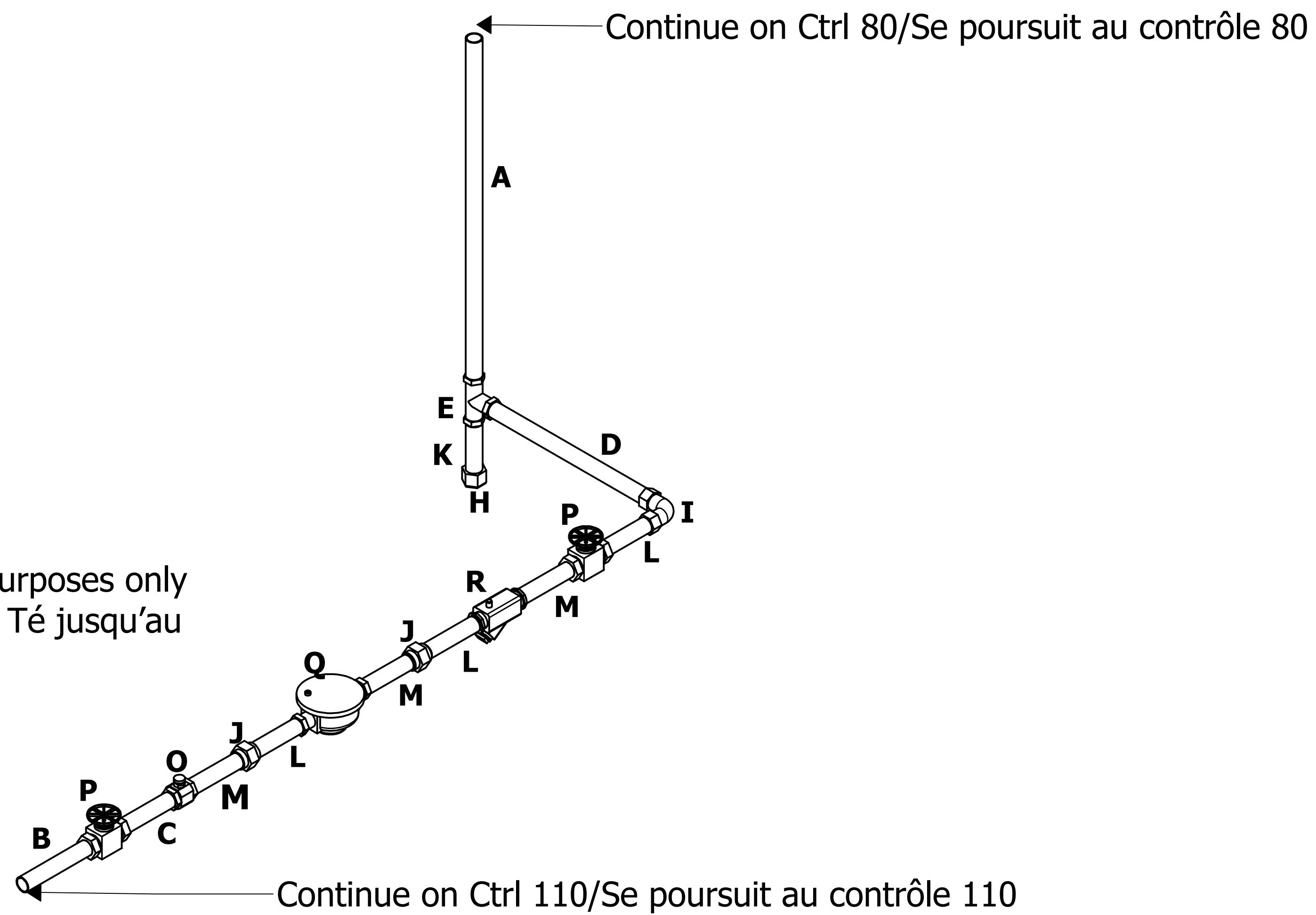

PARTS LIST / LISTE DES PIÈCES

ITEM/Article	QTYQTÉ	DESCRIPTION	
A	1	3/4" STD(287) TH X TH extrémités filetéés, 3/4 po STD(287)	436 mm
B	1	3/4" STD(287) TH XTH extrémités filetéés, 3/4 po STD(287)	151 mm
C	1	3/4" STD(287) TH X TH extrémités filetéés, 3/4 po STD(287)	152 mm
D	1	3/4" STD(287) TH XTH extrémités filetéés, 3/4 po STD(287)	440 mm
E	1	3/4" 150# TH TEE UNION EN T FILETÉ no 150 3/4 po	
H	1	3/4" TH CAP CAPUCHON FILETÉ 3/4 po	
I	1	3/4" 90 150# TH ELBOW COUDE À 90° FILETÉ no 150 3/4 po	
J	2	3/4" 150# TH UNION / UNION FILETÉ no 150 3/4 po	
K	1	3/4" 75 Lg TBE NIPPLE PIPE / MAMELON FILETÉ LONGUEUR 75, po	
L	3	3/4" 102 Lg TBE NIPPLE PIPE MAMELON FILETÉ LONGUEUR 102	
M	3	3/4" 114 Lg TBE NIPPLE PIPE/ MAMELON FILETÉ LONGUEUR 114, 3/4 po	
O	1	3/4" TH CHECK VALVE 9 lb CLAPET ANTIRETOUR DE 9 lb FILETÉ 3/4 po	
P	2	3/4" TH GATE VALVE 6 lb ROBINET-VANNE DE 6 lb FILETÉ 3/4 po	
Q	1	3/4" STEAM TRAP 9 lb PURGEUR DE VAPEUR DE 9 lb FILETÉ 3/4 po	
R	1	3/4" TH STRAINER 7 lb FILTRE EN Y DE 7 lb FILETÉ 3/4 po	

DIM 175 mm of CENTER OF TEE to CENTER of TEE / La dimension de 175 mm part du CENTRE DU Té jusqu'au CENTRE du Té

DRAWN/DESSINÉ PAR GUY PERRON	2022-02-26	GP CAD Designs
TITLE / TITRE Skills Canada Steamfitter 2022/Montage de tuyaux à vapeur – Compétences Canada 2022		
SIZE D	DWG NO / NO DE DESSIN LP Steam Condensate Control No 100111 Condensat de vapeur basse pression No 100111	REV 2
SCALE/Echelle N/A/S/Ø	SHEET 3 OF 12 DE	