

4

3

2

1

NOTE:  
ALL DIMENSIONS IN MILLIMETERS / KILOGRAMS  
ALL MATERIAL STAINLESS STEEL  
SEE OTHER SHEETS FOR PARTS AND WELDING  
DETAILS

NOTE:  
TOUTES LES DIMENSIONS EN MILLIMÈTRES /  
KILOGRAMMES  
TOUS LES MATÉRIAUX EN ACIER INOXYDABLE  
VOIR LES AUTRES FICHES POUR LES PIÈCES ET LES  
DÉTAILS DE SOUDURE

**BILL OF MATERIALS/LISTE DES MATÉRIAUX**

ITEM	QTY	T	W	L	Total Wt	Wt Units
A	1	2.00	200	210	0.66	kg
B	2	2.00	80	120	0.00	kg
C	2	2.00	85	165	0.44	kg
D	2	2.00	40	85	0.11	kg
E	2	2.00	40	80	0.10	kg
F	1	2.00	165	177	0.46	kg
G	1	2.00	56	97	0.09	kg
H	2	2.00	38	64	0.08	kg
J	1	2.00	165	177	0.46	kg
K	2	2.00	60	70	0.13	kg
L	1	THRD NIPPLE - SIZE TBD				kg
					2.52	kg

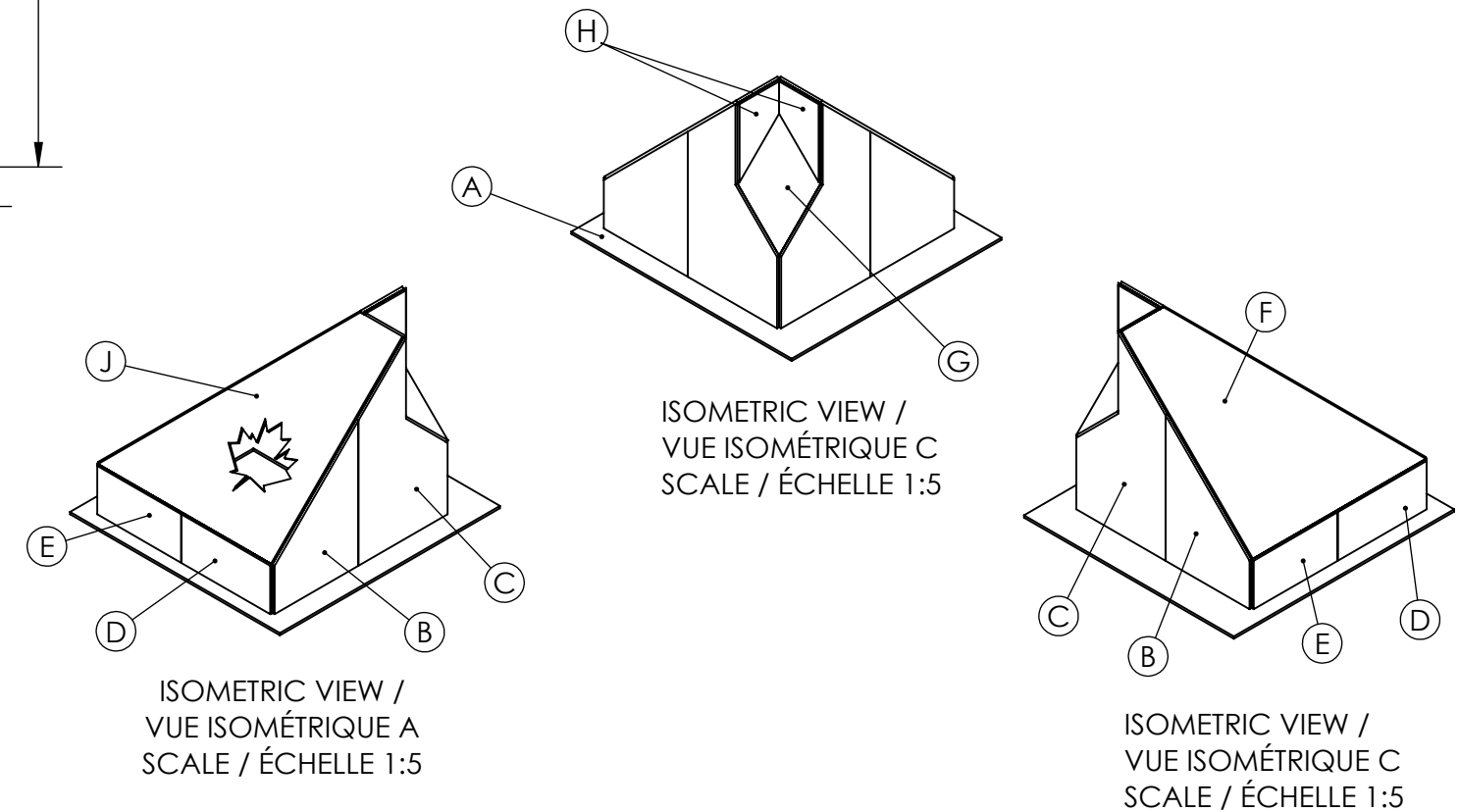
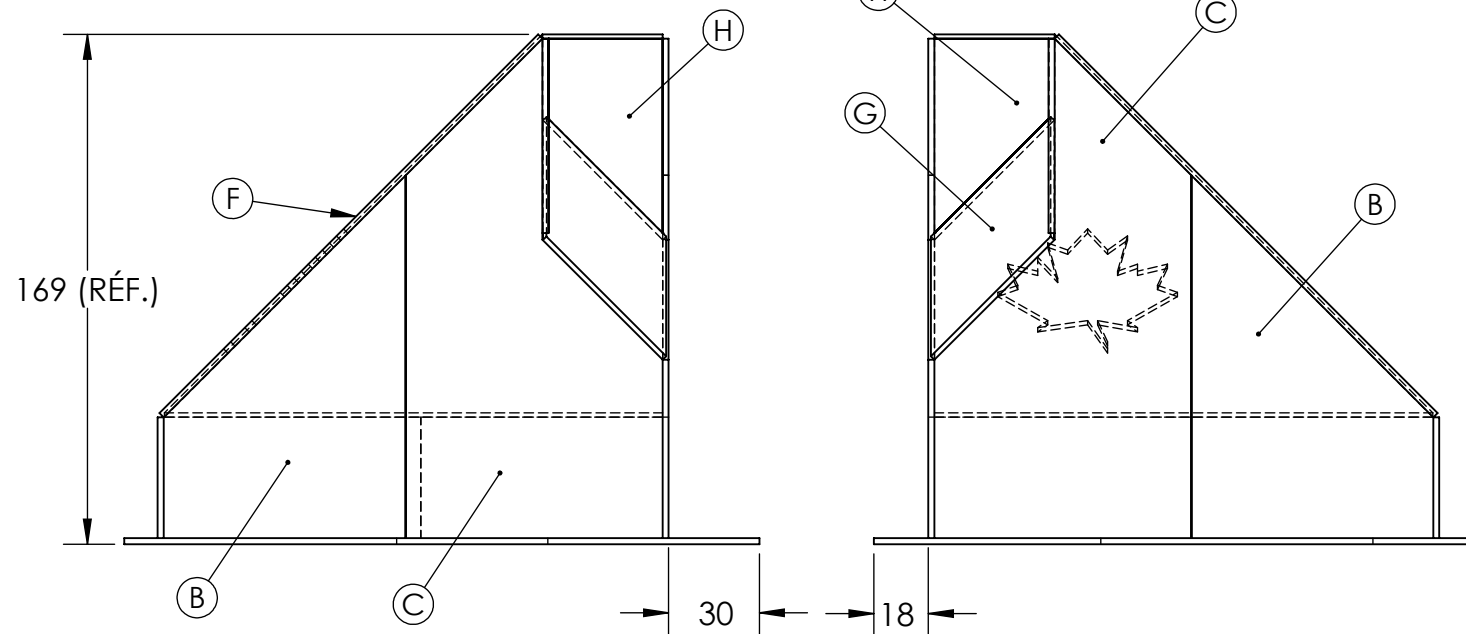
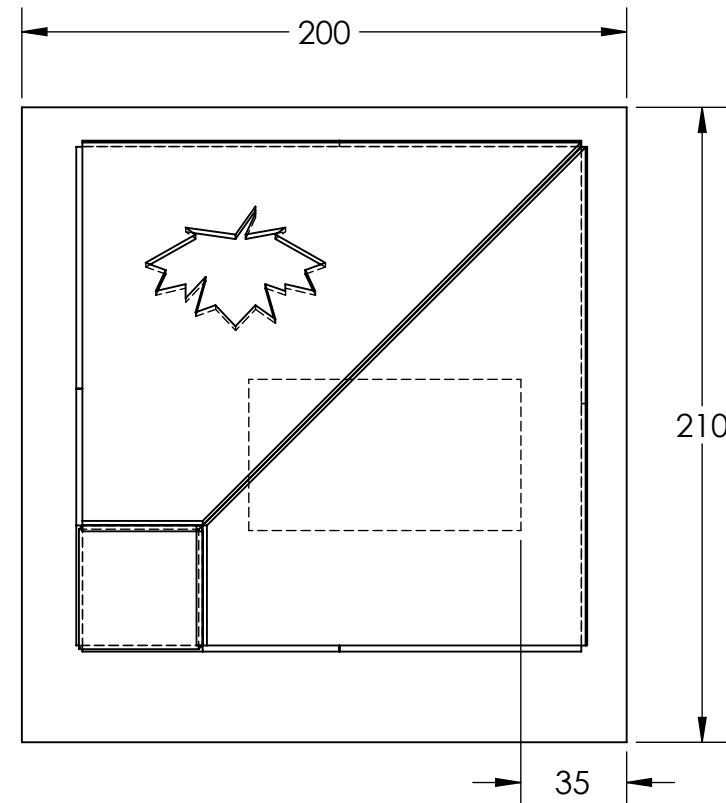

ALL DIMENSIONS IN MILLIMETERS/TOUTES LES DIMENSIONS SONT EN MILLIMÈTRES



WINNIPEG 2023

<b>TITLE:</b> SCNC 2023 - POST-SECONDARY DAY 2 OCMT 2023 - POST-SECONDAIRE JOUR 2 MINT / MONNAIE - ASSEMBLY / ASSEMBLAGE				<b>SHEET #</b> <b>NO. DE PAGE:</b> 1 OF 3	<b>SIZE/TAILLE:</b> B
<b>DWG. NO.:</b> SCC2023-SP-2	<b>REV.:</b> 2	<b>SCALE</b> <b>ÉCHELLE:</b> 1:2.5	<b>DESIGN BY:</b> T. PUNTON	<b>DRAWN BY:</b> J. HYDE	
			<b>DATE:</b> 2022-11-11		

4

3

2

1

4

3

2

1

NOTE:

- ALL WELDING TO BE DONE WITH GTAW / TOUTES LES SOUDURES DOIVENT ÊTRE EFFECTUÉES AVEC GTAW
- TACK ENTIRE PROJECT PRIOR TO STARTING WELDS, YOU MUST OBTAIN A SIGN-OFF FROM THE TECHNICAL COMMITTEE AFTER FITTING AND BEFORE WELDING / POINTER TOUS LES COMPOSANTS ENSEMBLE AVANT DE COMMENCER LE SOUDAGE, VOUS DEVEZ OBTENIR L'APPROBATION DU COMITÉ TECHNIQUE APRÈS L'ASSEMBLAGE ET AVANT LE SOUDAGE
- ALL WELDING MUST BE DONE WITH BASE PLATE "A" SITTING FLAT ON TABLE / LA PLAQUE D'ASSISE « A » DOIT ÊTRE À PLAT SUR LA TABLE DURANT TOUTES LES ACTIVITÉS DE SOUDURE
- NO AUTOGENOUS WELDS ALLOWED / AUCUNE SOUDURE AUTOGÈNE AUTORISÉE
- NO REWELDING OR REMELTING / AUCUNE RESOUDURE OU REFONTE
- NO ALTERING JOINTS / PAS DE JOINTS MODIFIÉS
- NO POST-WELD CLEANING ALLOWED / AUCUN NETTOYAGE APRÈS SOUDURE AUTORISÉ

ITEMS A AND F, TYP. / ÉLÉMENTS A ET F, TYPIQUES,

NO WELD ON PURGE PLATE (K)  
OR PURGE NIPPLE (L) / AUCUNE SOUDURE SUR LA  
PLAQUE (K) OU LE MAMELON DE PURGE (L)

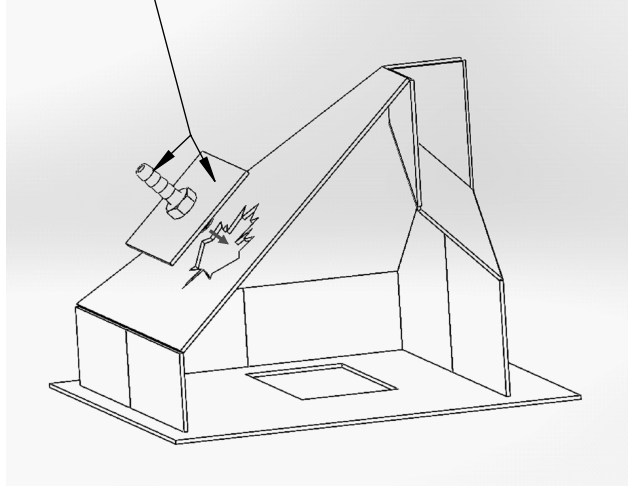

VIEW E / VUE E  
PURGE PLATE ASSEMBLY DETAILS,  
ITEM B & C REMOVED /  
DÉTAILS DE L'ASSEMBLAGE  
DE LA PLAQUE DE PURGE,  
ÉLÉMENT B & C SUPPRIMÉ

SECTION D-D  
SCALE 1 : 2.5

ALL DIMENSIONS IN MILLIMETERS/TOUTES LES DIMENSIONS SONT EN MILLIMÈTRES

<b>TITLE:</b> SCNC 2023 - POST-SECONDARY DAY 2 OCMT 2023 - POST-SECONDAIRE JOUR 2 MINT / MONNAIE - WELDS / SOUDURES		<b>SHEET #</b> <b>NO. DE PAGE:</b> 2 OF 3	<b>SIZE/TAILLE:</b> B
<b>DWG. NO.:</b> SCC2023-SP-2	<b>REV.:</b> 2	<b>SCALE</b> <b>ÉCHELLE:</b> 1:2.5	<b>DESIGN BY:</b> T. PUNTON <b>DRAWN BY:</b> J. HYDE <b>DATE:</b> 2022-11-11



4

3

2

1

4

3

2

1

**BILL OF MATERIALS**

ITEM	QTY	T	W	L	Total Wt	Wt Units
A	1	2.00	200	210	0.66	kg
B	2	2.00	80	120	0.00	kg
C	2	2.00	85	165	0.44	kg
D	2	2.00	40	85	0.11	kg
E	2	2.00	40	80	0.10	kg
F	1	2.00	165	177	0.46	kg
G	1	2.00	56	97	0.09	kg
H	2	2.00	38	64	0.08	kg
J	1	2.00	165	177	0.46	kg
K	1	2.00	60	70	0.07	kg
L	1	NIPPLE / LE MAMELON				
					2.45	kg

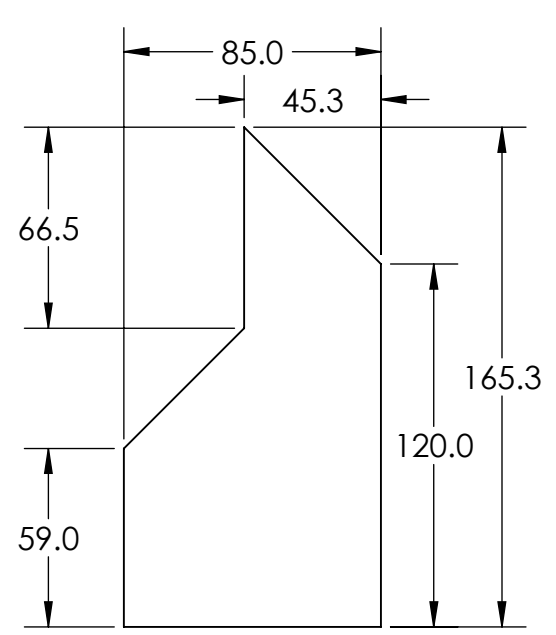
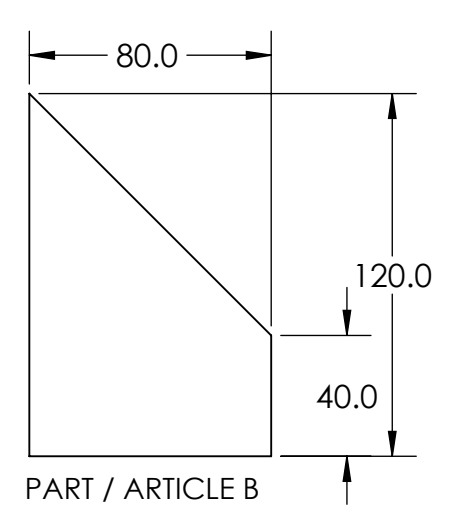
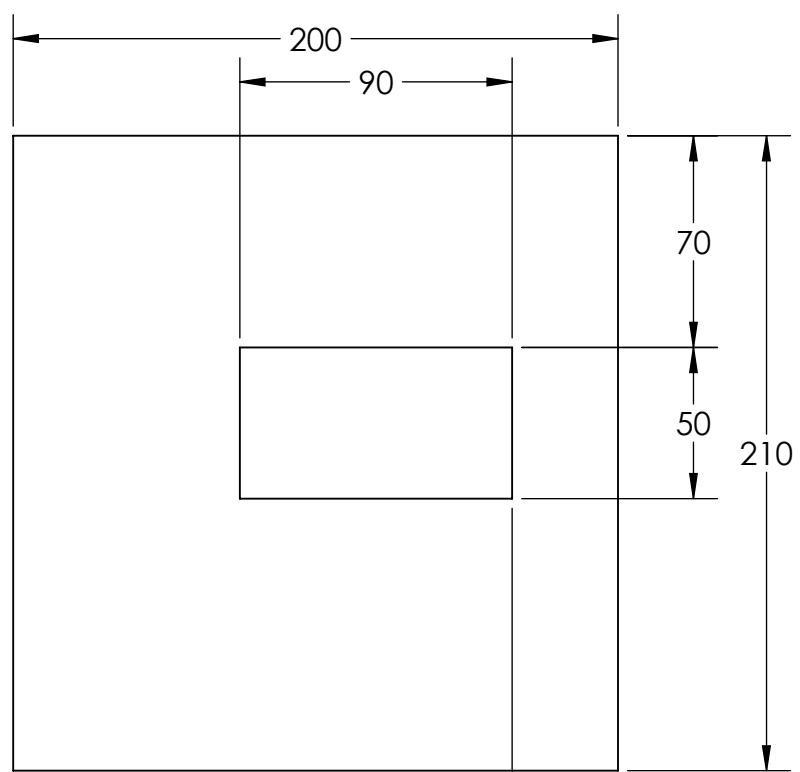

PART / ARTICLE A

PART / ARTICLE B

PART / ARTICLE C

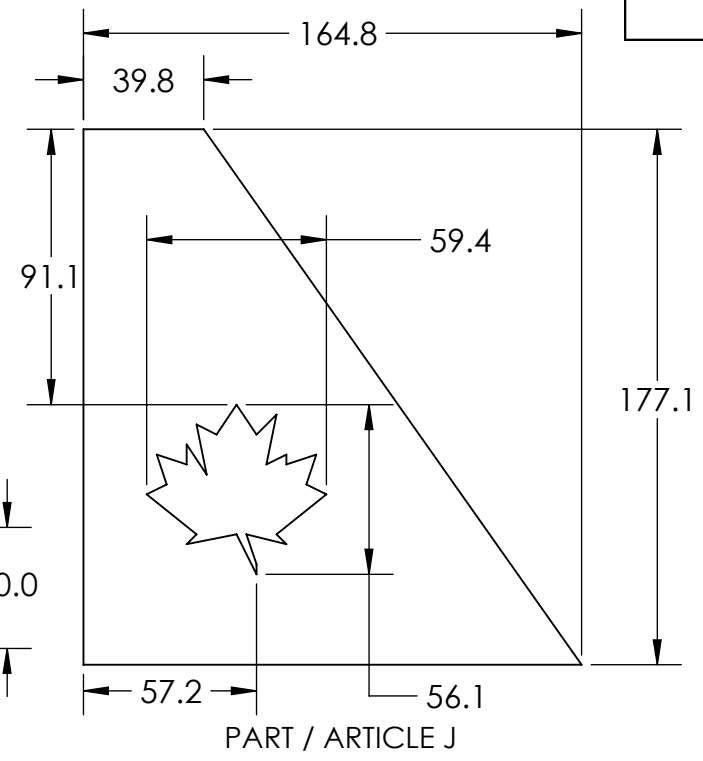
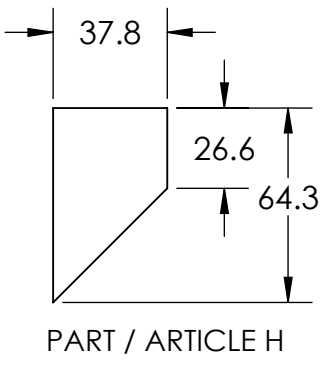
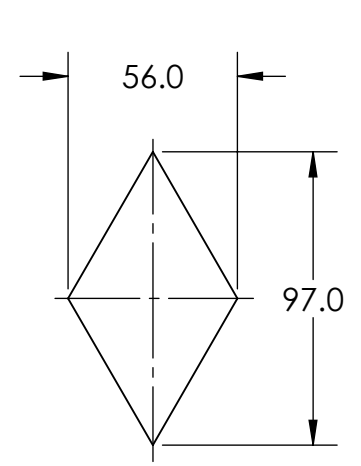
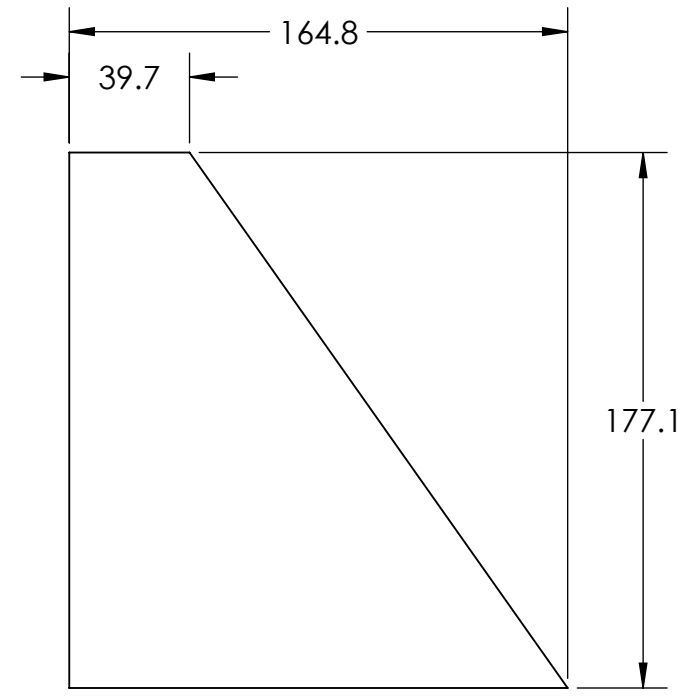

PART / ARTICLE F

PART / ARTICLE G

PART / ARTICLE H

PART / ARTICLE J

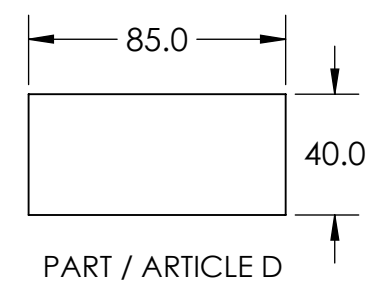

PART / ARTICLE D

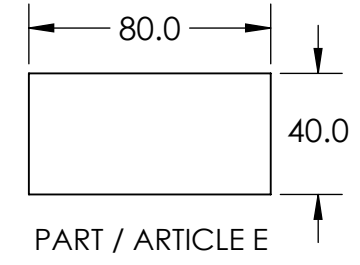

PART / ARTICLE E

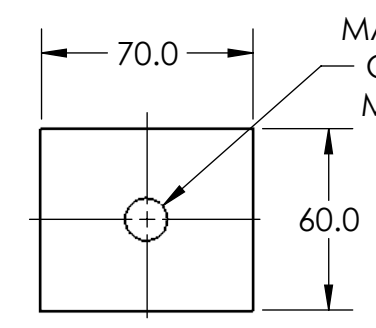

PART / ARTICLE K  
(PURGE PLATE /  
PLAQUE DE PURGE)

MATCH PURGE NIPPLE /  
CORRESPONDRE AU  
MAMELON DE PURGE

ALL DIMENSIONS IN MILLIMETERS/TOUTES LES DIMENSIONS SONT EN MILLIMÈTRES



<b>TITLE:</b> SCNC 2023 - POST-SECONDARY DAY 2 OCMT 2023 - POST-SECONDAIRE JOUR 2 MINT / MONNAIE - PARTS / LES PIÈCES			<b>SHEET #</b> <b>NO. DE PAGE:</b> 3 OF 3	<b>SIZE/TAILLE:</b> B
<b>DWG. NO.:</b> SCC2023-SP-2	<b>REV.:</b> 2	<b>SCALE</b> <b>ÉCHELLE:</b> 1:2.5	<b>DESIGN BY:</b> T. PUNTON	
			<b>DRAWN BY:</b> J. HYDE	
			<b>DATE:</b> 2022-11-11	

4

3

2

1