

4

3

2

1

NOTE:

- ALL MATERIAL MILD STEEL PLATE
- TACK WELD ENTIRE ASSEMBLY, ATTAIN STAMP FROM COMMITTEE, AND ONLY THEN BEGIN WELDING
- READ ALL NOTES ON ALL SHEETS FOR FUTHER, IMPORTANT INSTRUCTIONS

REMARQUES:

- MATÉRIAU; TÔLE EN ACIER DOUX TOUT SOUDEZ PAR POINTAGE TOUT L'ASSEMBLAGE,
- OBTENEZ LE POINÇON DE COMITÉ, ET SEULEMENT ENSUITE COMMENCEZ LE SOUDAGE
- LISEZ TOUTES LES NOTES SUR TOUTES LES FEUILLES CONCERNANT LES INSTRUCTIONS IMPORTANTES

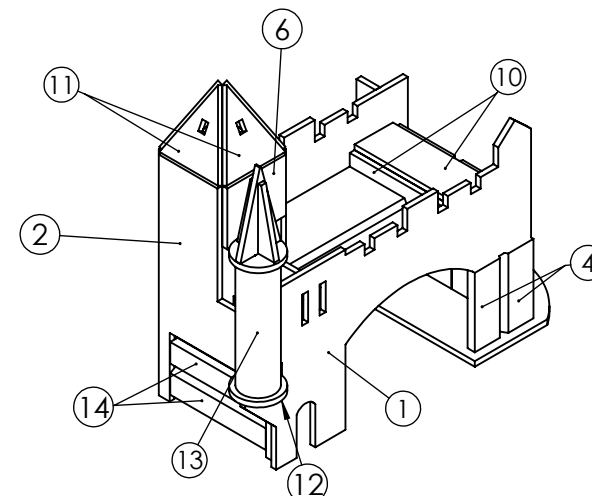
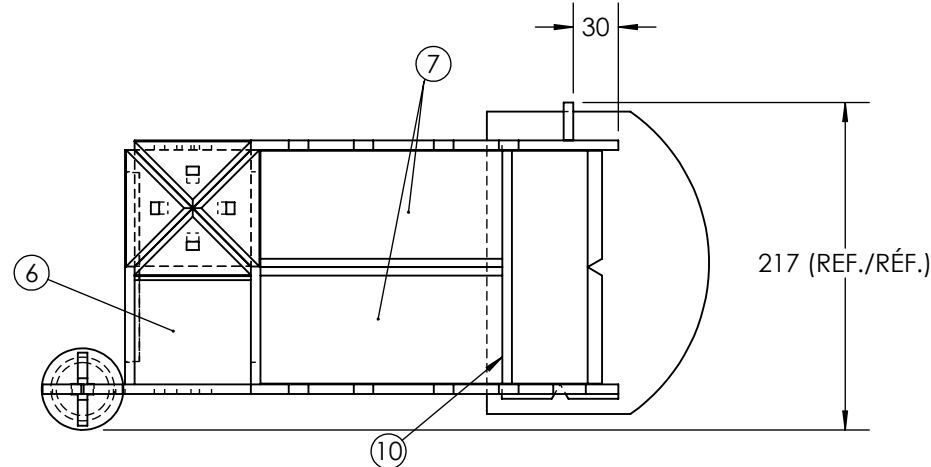

ISOMETRIC VIEW A /
VUE ISOMÉTRIQUE A
SCALE/ÉCHELLE 1 : 7

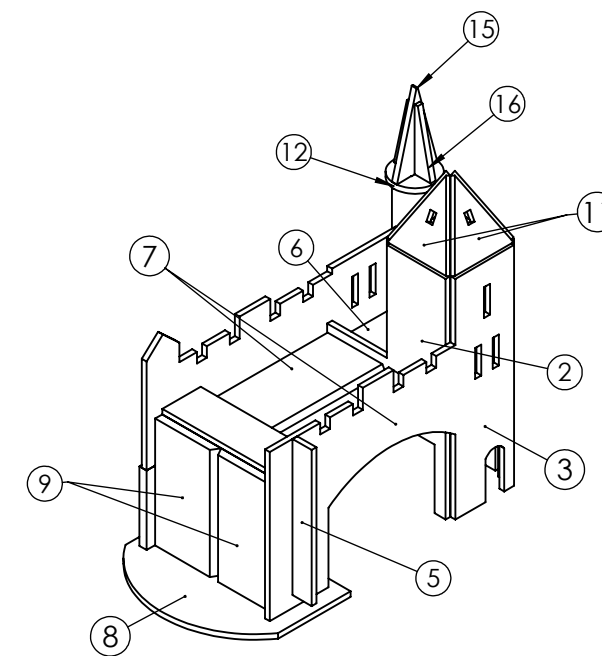

ISOMETRIC VIEW B /
VUE ISOMÉTRIQUE B
SCALE / ÉCHELLE 1:7

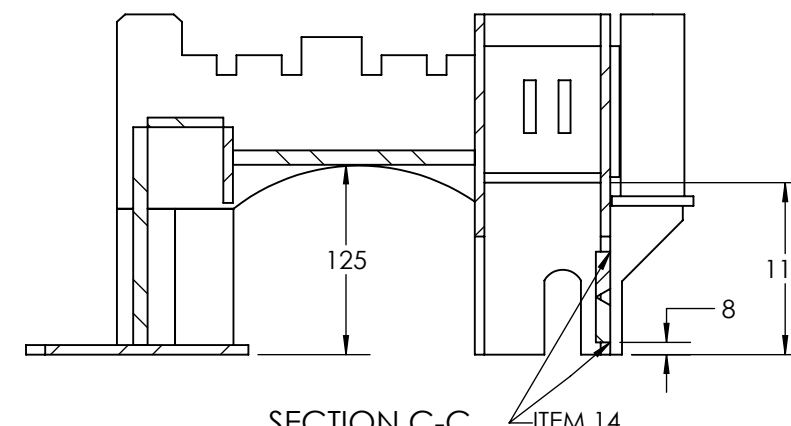
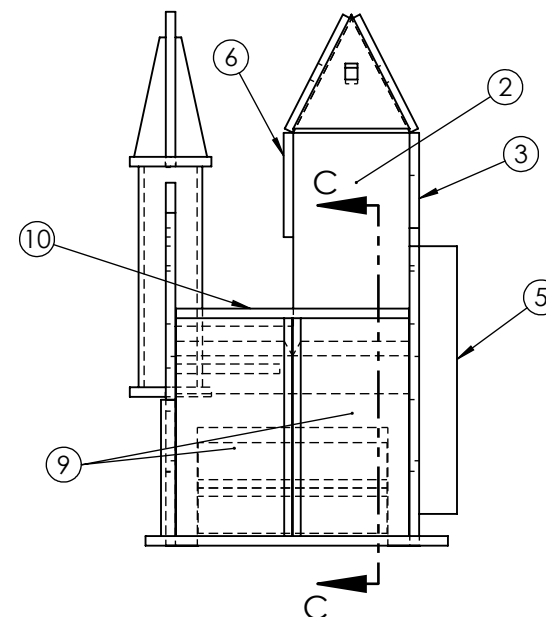
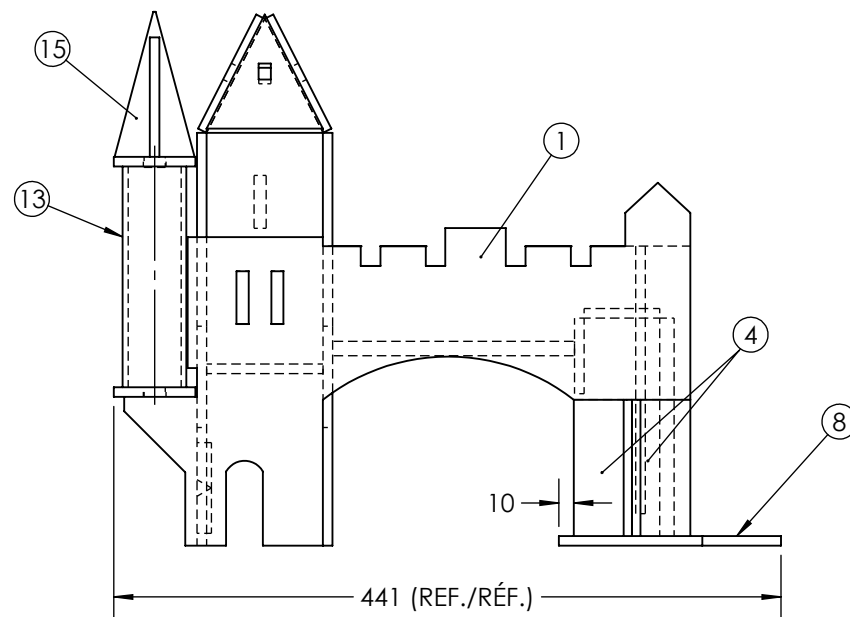
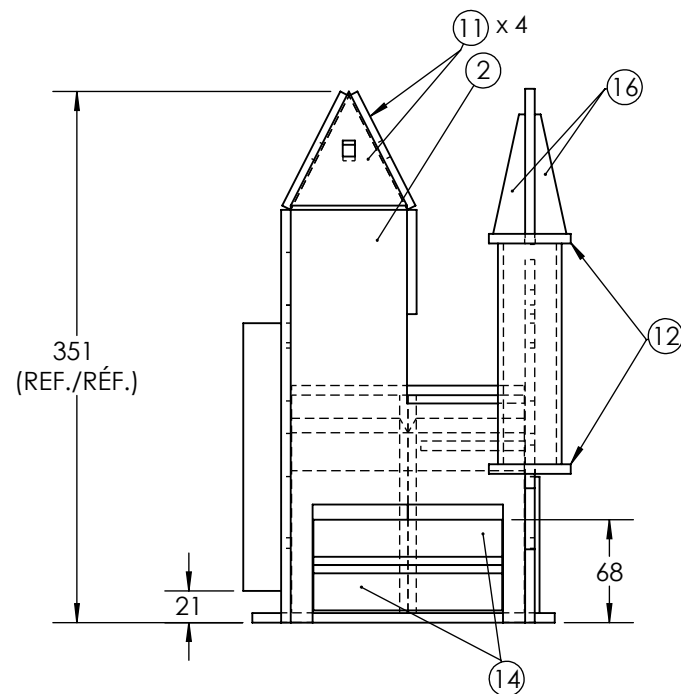

ALL DIMENSIONS IN MILLIMETERS/TOUTES LES DIMENSIONS SONT EN MILLIMÈTRES



TITLE: SCNC 2024 - SECONDARY DAY 1 OCMT 2024 - SECONDAIRE JOUR 1 PORTE SAINT-LOUIS		SHEET # NO. DE PAGE: 1 OF 3	SIZE/TAILLE: B
DWG. NO.: SCNC24-S1	REV.: 2	SCALE ÉCHELLE: 1:5	DRAWN BY: J. HYDE DATE: 2023-10-17

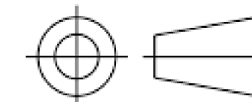

4

3

2

1

4

3

2

1

ER49S-6
DOWNHAND / PROGRESSION
EN VERTICAL DESCENDANT
TYP.

ER49S-6

E4918
27-75

E4310 ROOT/ RACINE
E4918 CAP / REMPLISSAGE

ER49S-6
ROOT DOWNHAND
/ RACINE DESCENDANT

B

B

SECTION E-E

TACK ONLY/
TACK SEULEMENT

NOTE

1. ALL WELDING MUST BE DONE WITH BASE PLATE "A" SITTING FLAT ON TABLE
2. YOU MUST OBTAIN A SIGN-OFF FROM THE TECHNICAL COMMITTEE AFTER FITTING AND BEFORE WELDING
3. GAP AND ROOT FACE FOR PREPARED VEE GROOVE WELDS --> YOUR CHOICE, SEE PAGE 3 FOR GROOVE PREPARATION DETAILS
4. ALL VERTICAL WELDING TO BE DONE IN UPHILL PROGRESSION, UNLESS NOTED

REMARQUE:

1. LA PLAQUE D'ASSISE « A » DOIT ÊTRE À PLAT SUR LA TABLE DURANT TOUTES LES ACTIVITÉS DE SOUDURE
2. VOUS DEVEZ OBTENIR L'APPROBATION DU COMITÉ TECHNIQUE APRÈS L'ASSEMBLAGE ET AVANT LE SOUDAGE
3. ESPACEMENT ET ECARTEMENT POUR LES SOUDURES EN V --> À VOTRE DISCRÉTION, VOIR PAGE 3 POUR LES DÉTAILS DE LA PRÉPARATION POUR LES SOUDURES EN V
4. TOUTES LES SOUDURES VERTICALES DOIVENT ÊTRE EXÉCUTÉES EN MONTANT, SAUF NOTE

ALL DIMENSIONS IN MILLIMETERS/TOUTES LES DIMENSIONS SONT EN MILLIMÈTRES

TITLE: SCNC 2024 - SECONDARY DAY 1 OCMT 2024 - SECONDAIRE JOUR 1 PORTE SAINT-LOUIS		SHEET # NO. DE PAGE: 2 OF 3	SIZE/TAILLE: B
DWG. NO.: SCNC24-S1	REV.: 2	SCALE ÉCHELLE: 1:5	DRAWN BY: J. HYDE DATE: 2023-10-17

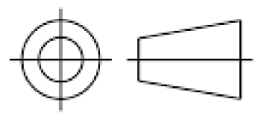

4

3

2

1

A

A

4

3

2

1

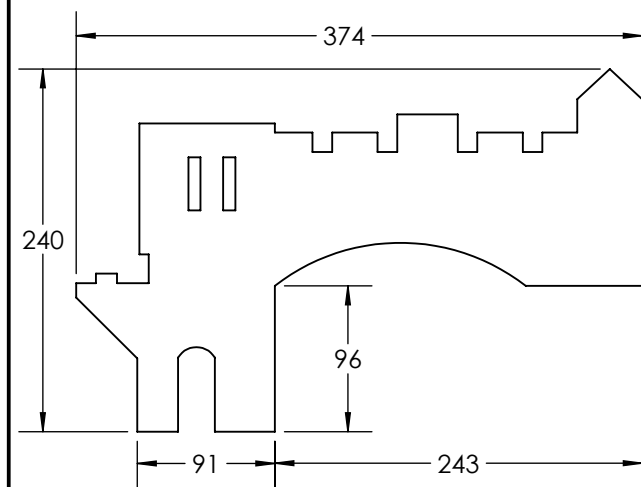

ARTICLE / ITEM 1

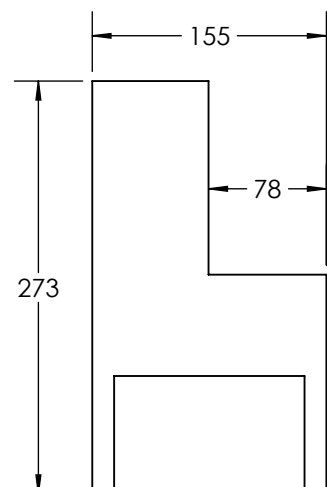

ARTICLE / ITEM 2

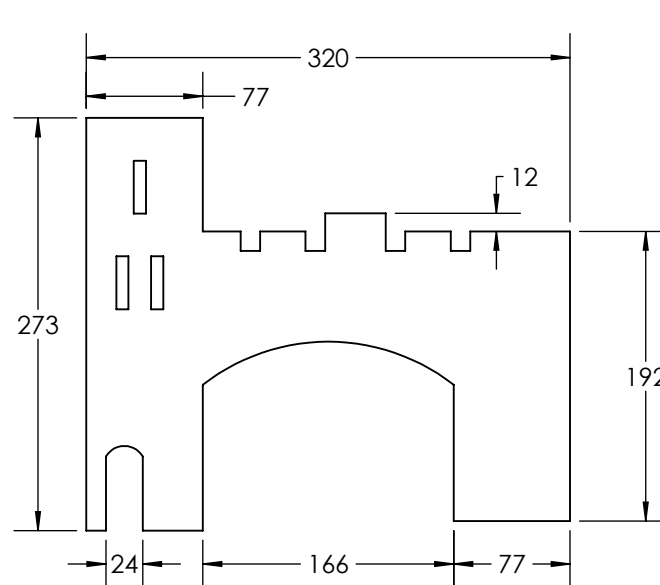

ARTICLE / ITEM 3

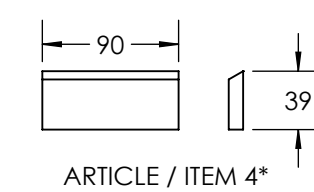

ARTICLE / ITEM 4*

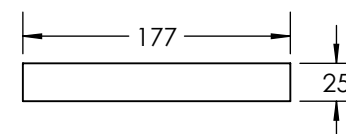

ARTICLE / ITEM 5

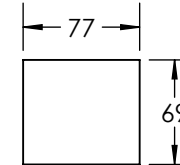

ARTICLE / ITEM 6

ITEM / ARTICLE	DESCRIPTION	QTY.
1	PL 6.35 x 240 x 374	1
2	PL 6.35 x 154 x 273	2
3	PL 6.35 x 273 x 320	1
4	PL 9.53 x 39 x 90*	2
5	PL 6.35 x 25 x 177	1
6	PL 6.35 x 69 x 77	2
7	PL 9.53 x 77 x 160*	2
8	PL 6.35 x 147 x 200	1
9	PL 9.53 x 77 x 144*	2
10	PL 6.35 x 50 x 154	2
11	PL 6.35 x 77 x 85	4
12	PL 6.35 x Ø54	2
13	PIPE (1-1/4" STD) ID35 x OD42 x 146	1
14	PL 9.53 x 30 x 125*	2
15	PL 6.35 x 53 x 103	1
16	PL 6.35 x 21 x 79	2

TOTAL ESTIMATED WEIGHT, BEFORE WELDING/
POIDS TOTAL ESTIMÉ, AVANT SOUDAGE: 15.3 KG

**PREPARED GROOVE DIMENSIONS /
DIMENSIONS DES RAINURES PRÉPARÉES**

* = ALL BEVEL AND VEE PREPARATIONS AS FOLLOWS:
* = PRÉPARER TOUTES LES SOUDURES EN V ET EN BISEAU COMME CECI :

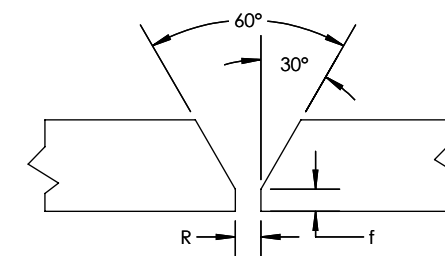

R and f are prepared to the preference of the competitor.
The dimension for the plates shown is to a feathered edge and any root gap must be accommodated in overall fitting dimensions.
R et f sont préparés selon les préférences du concurrent ou de la concurrente. Les dimensions des plaques présentées tiennent compte d'un rebord aminci et tout espacement des racines doit être pris en compte dans l'ensemble des dimensions d'assemblage.

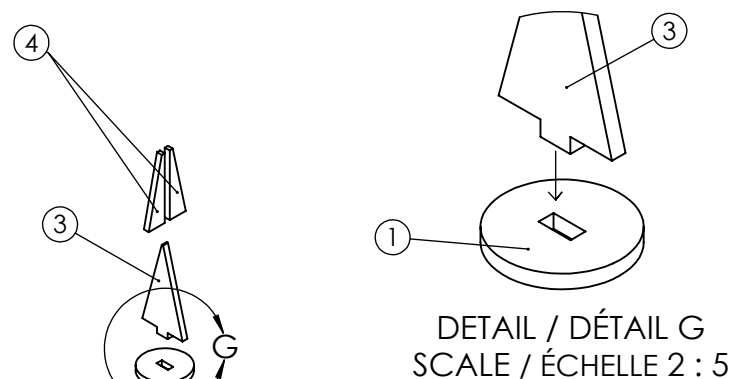

DETAIL / DÉTAIL G
SCALE / ÉCHELLE 2 : 5

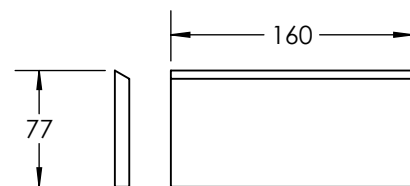

ARTICLE / ITEM 7*

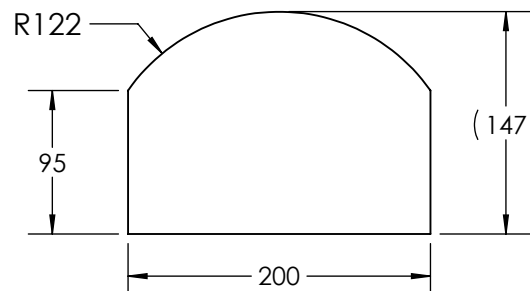

ARTICLE / ITEM 8

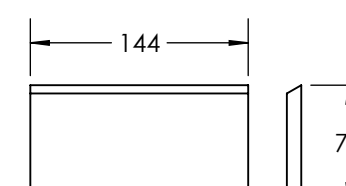

ARTICLE / ITEM 9*

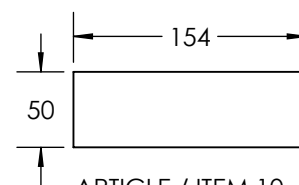

ARTICLE / ITEM 10

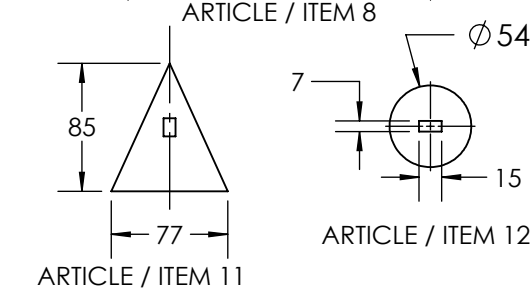

ARTICLE / ITEM 11

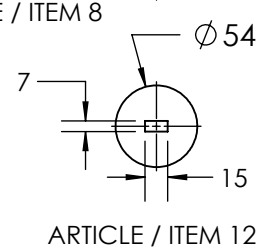

ARTICLE / ITEM 12

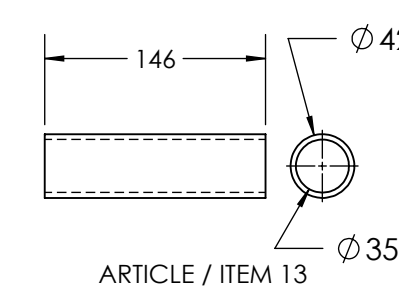

ARTICLE / ITEM 13

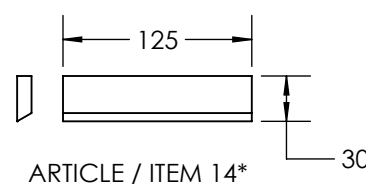

ARTICLE / ITEM 14*

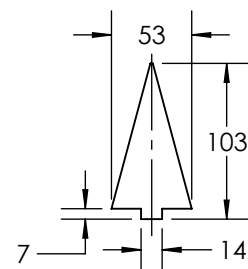

ARTICLE / ITEM 15

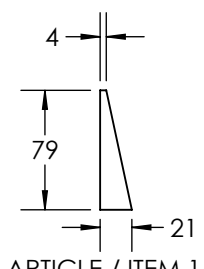

ARTICLE / ITEM 16

VIEW F
SLOTTED PARTS / COMPOSANTS FENDUS
SCALE / ÉCHELLE

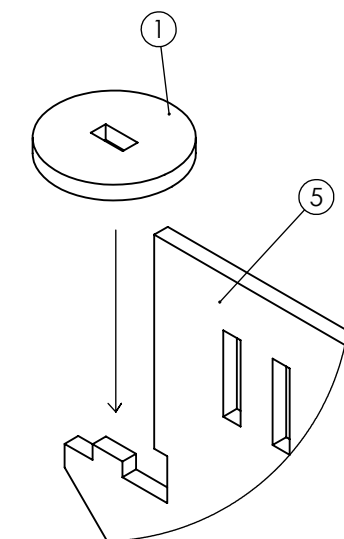

DETAIL / DÉTAIL H
SCALE / ÉCHELLE 2 : 5

ALL DIMENSIONS IN MILLIMETERS/TOUTES LES DIMENSIONS SONT EN MILLIMÈTRES

TITLE: SCNC 2024 - SECONDARY DAY 1 OCMT 2024 - SECONDAIRE JOUR 1 PORTE SAINT-LOUIS		SHEET # NO. DE PAGE: 3 OF 3	SIZE/TAILLE: B
DWG. NO.: SCNC24-S1	REV.: 2	SCALE ÉCHELLE: 1:5	DRAWN BY: J. HYDE DATE: 2023-10-17

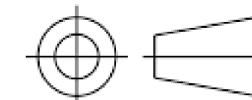

4

3

2

1