



NUMÉRATIE



LECTURE

**BANC  
 D'ENTRÉE**

VUE DE DROITE, DE  
 FACE ET DE DESSUS  
 (POSTSECONDAIRE)

notes:

ÉCHELLE - 1:5

PAGE 1 DE 3

dessiné par:  
 mm

14/10/2025

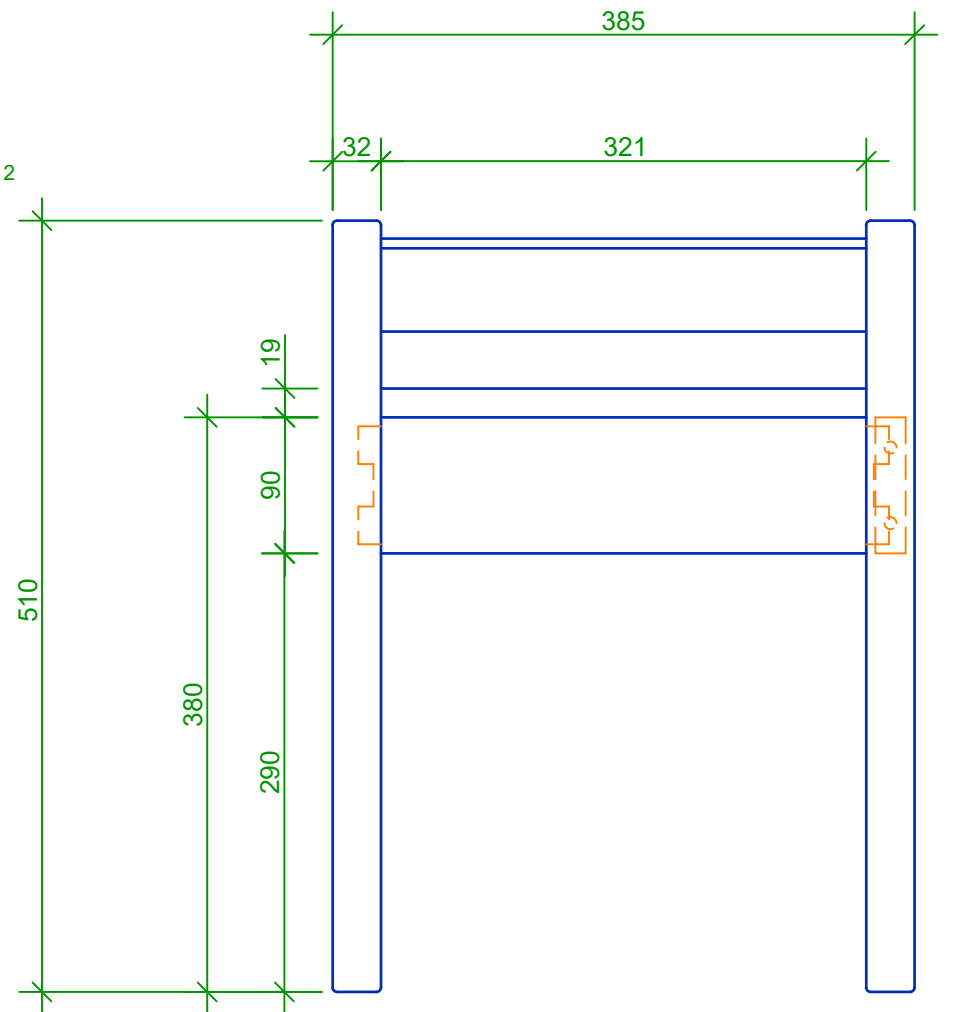
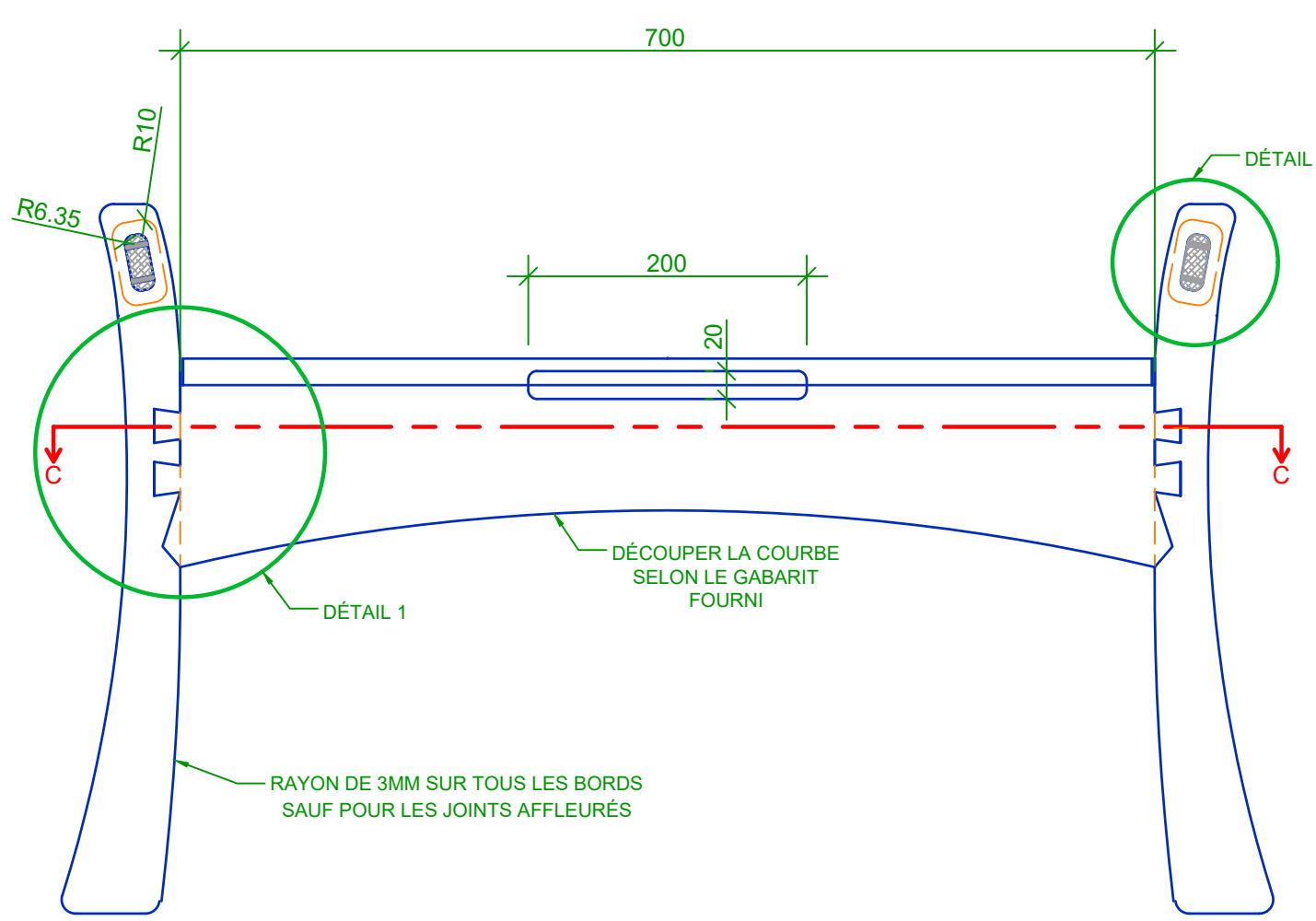
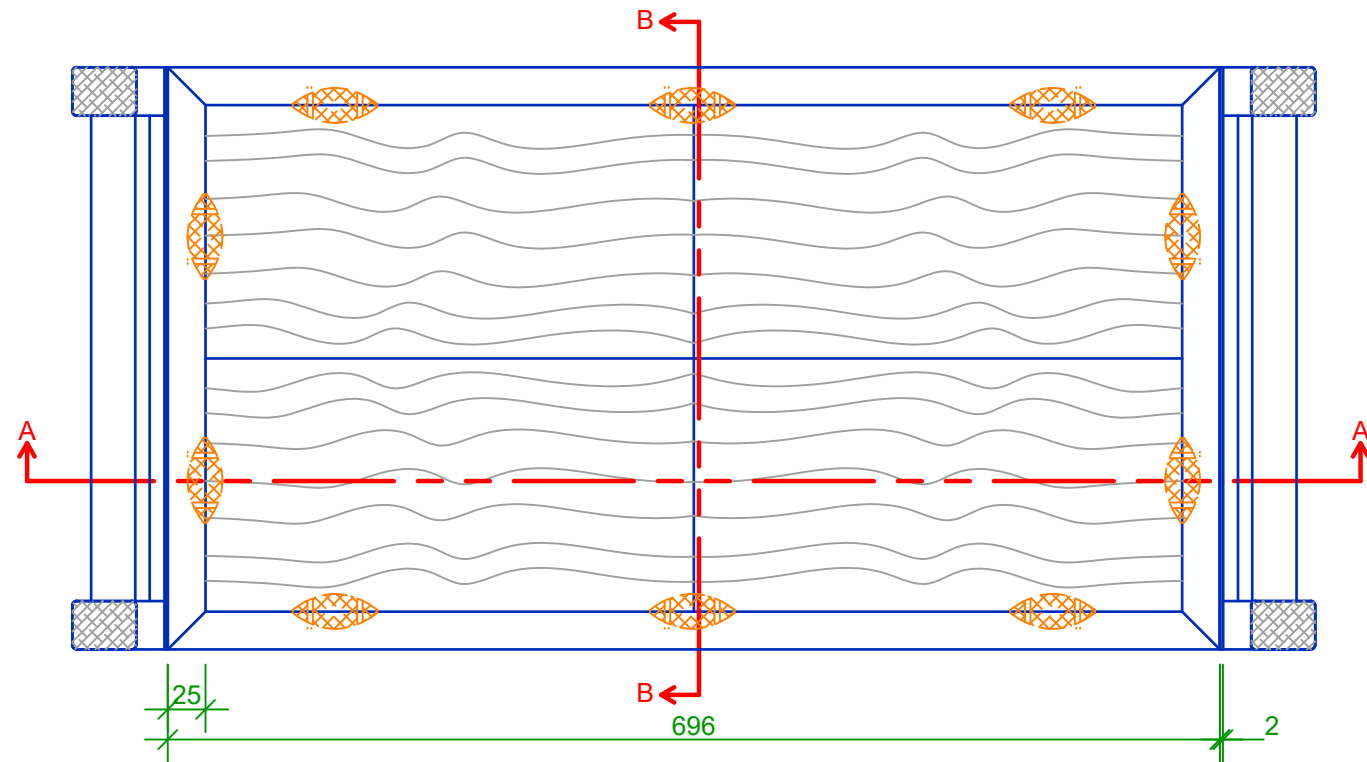

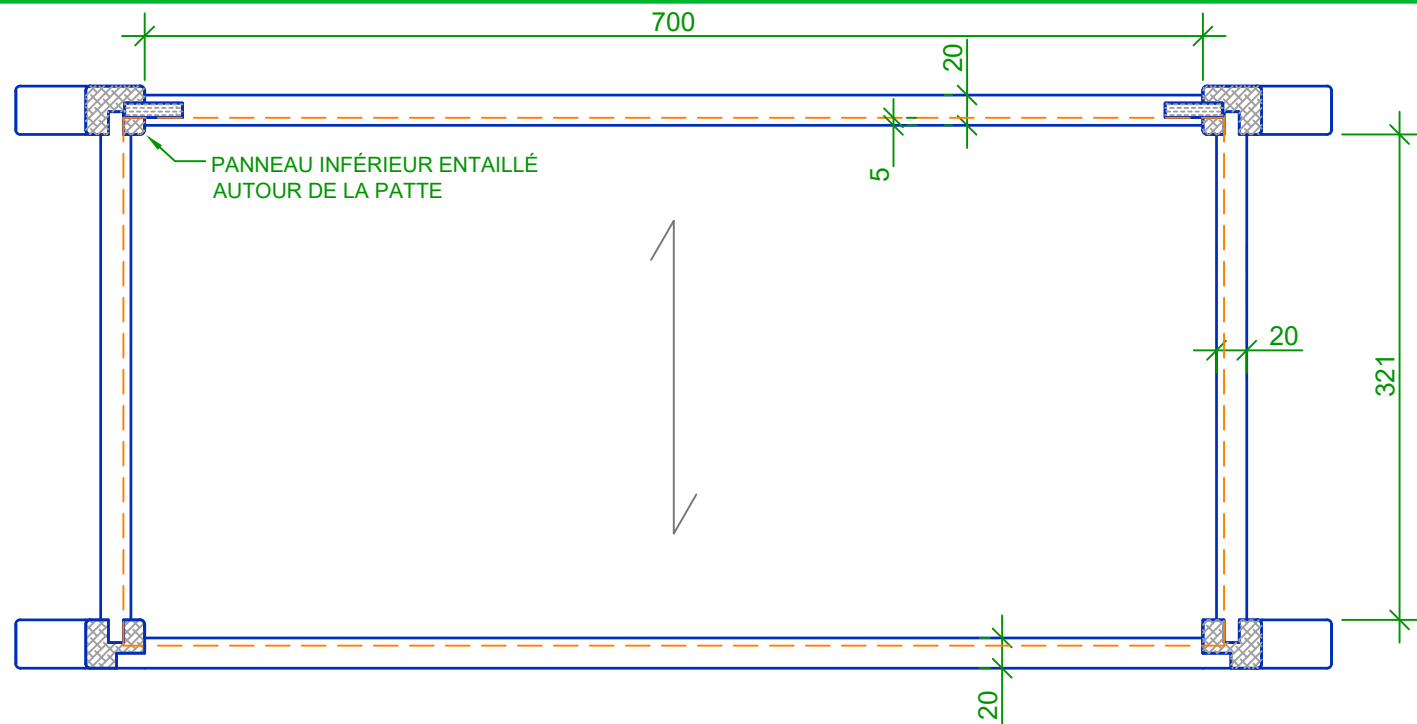

**COUPE C-C**

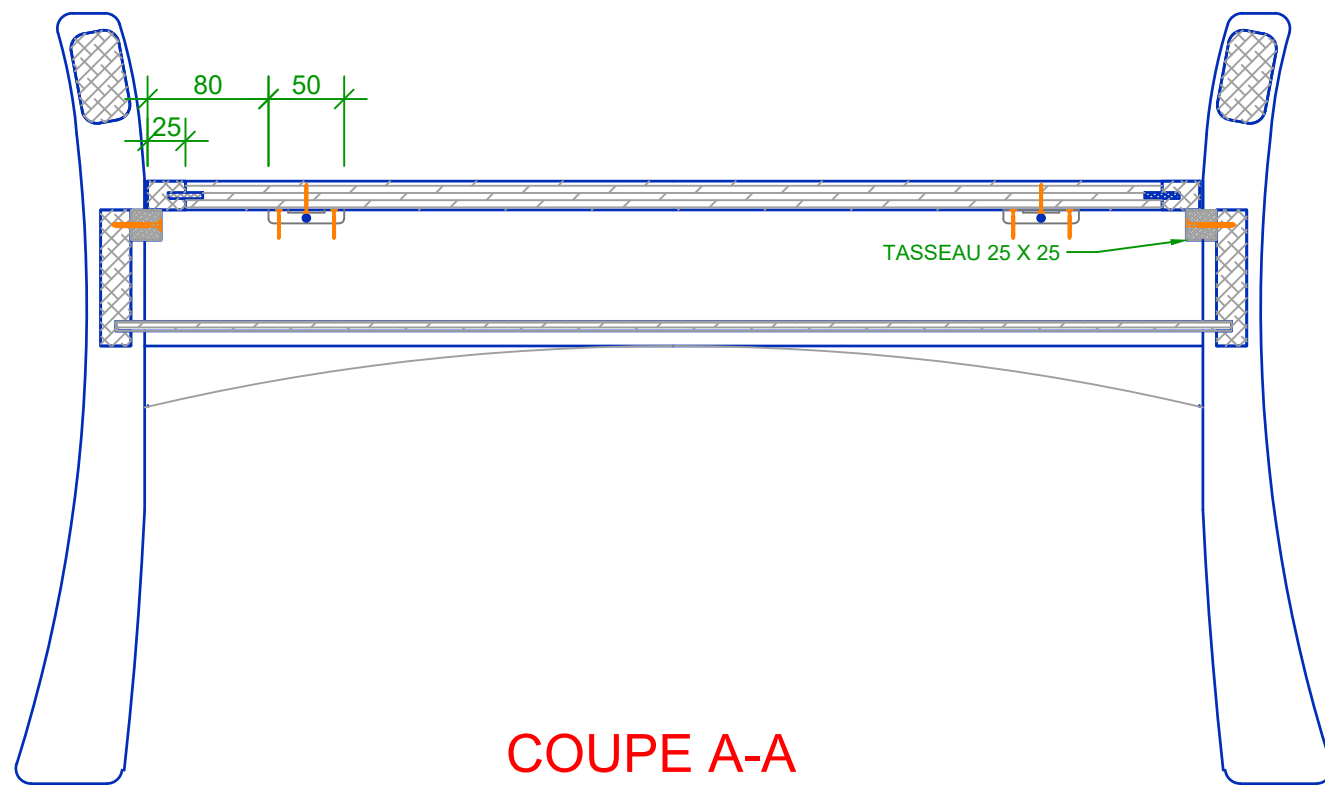

**COUPE A-A**

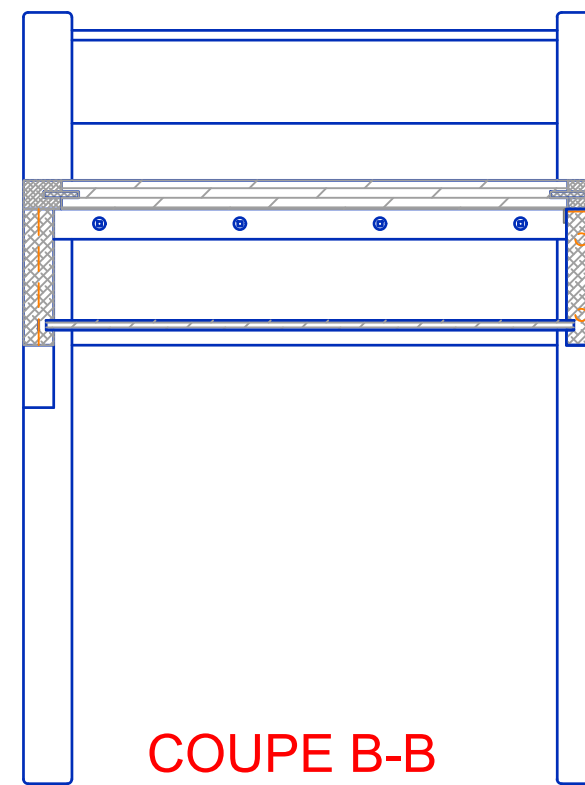

**COUPE B-B**



NUMÉRATIE



LECTURE

**OCMT 2026  
ÉBÉNISTERIE  
(MÉTIER 24)  
PROJET D'ÉPREUVE**

**BANC  
D'ENTRÉE**

**COUPES (NIVEAU  
POSTSECONDAIRE)**

notes:

**ECHELLE- 1:5**

**PAGE 2 DE 3**

**DESSINÉ PAR:  
mm**

**14/10/2025**

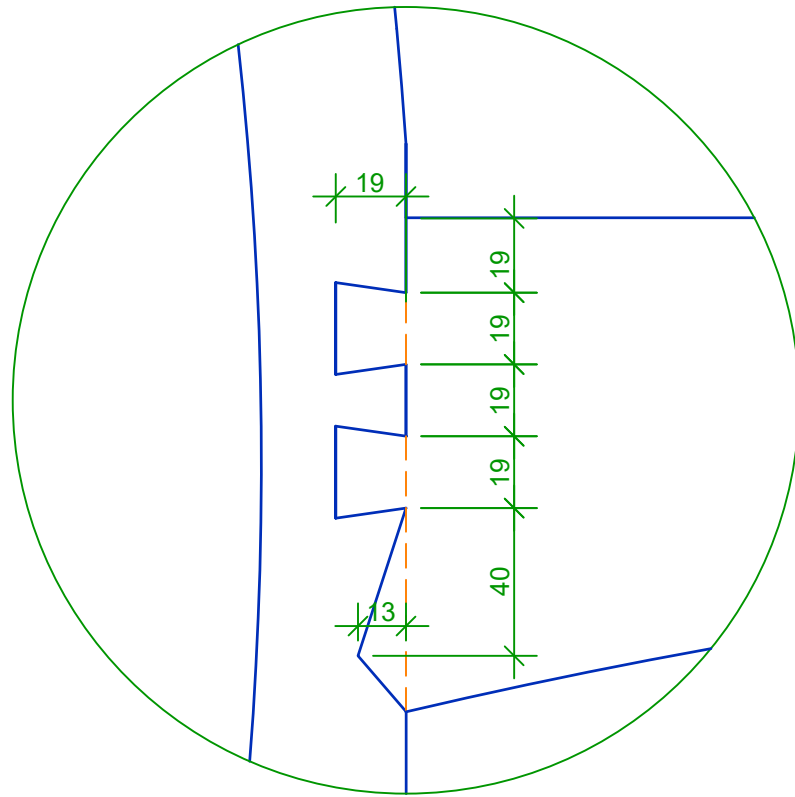

DÉTAIL QUEUE D'ARONDE AVEC COUPE BIAISE - ÉCHELLE 1:2

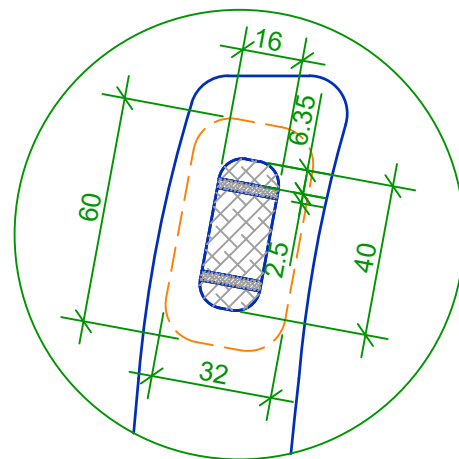

ASSEMBLAGE DE LA TRAVERSE SUPÉRIEURE - ÉCHELLE 1:2

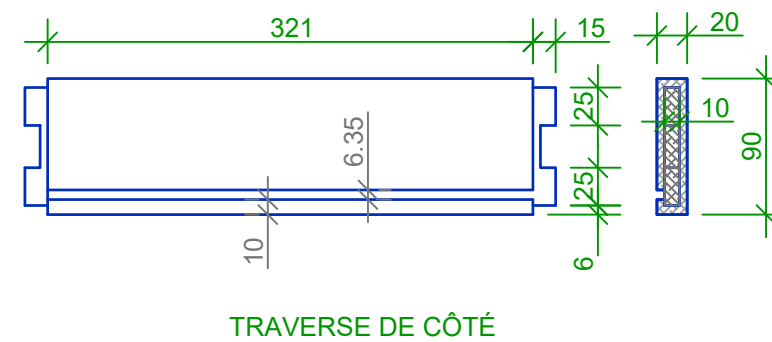
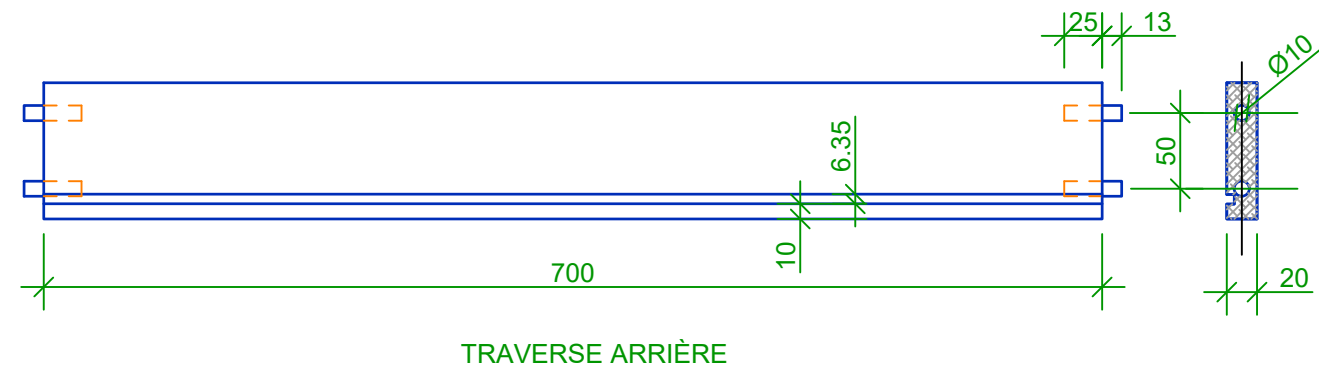
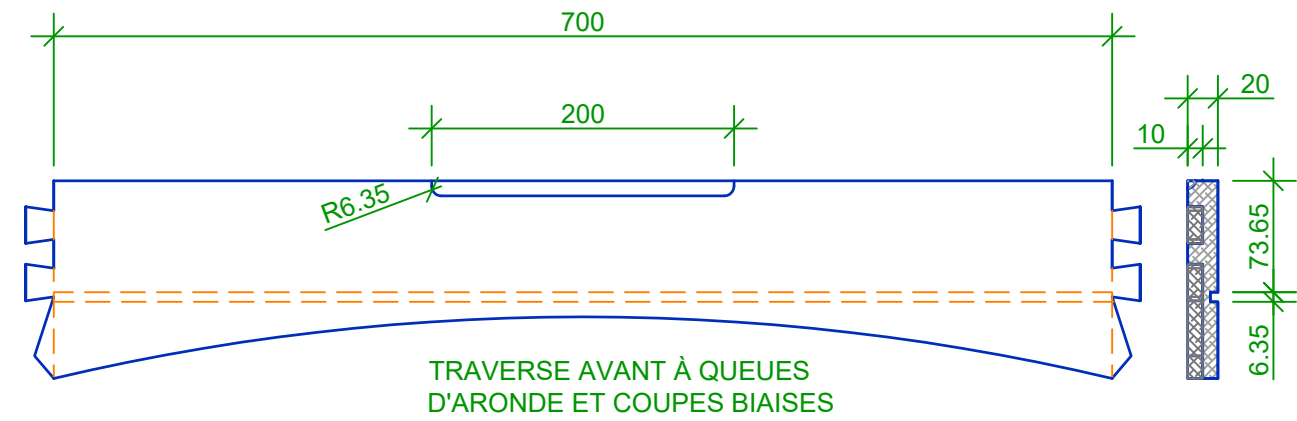

OCMT 2026  
ÉBÉNISTERIE  
(MÉTIER 24)  
PROJET D'ÉPREUVE

**BANC  
D'ENTRÉE**

DÉTAILS  
D'ASSEMBLAGES  
(POSTSECONDAIRE)

notes:

ÉCHELLE - 1:5  
OU TEL QUE MONTRÉ

PAGE 3 DE 3

DESSINÉ PAR:  
mm

14/10/2025

 SkillsCompétences  
Canada  
Toronto2026