

OCMT 2026  
ÉBÉNISTERIE  
(MÉTIER 24)  
PROJET  
D'ÉPREUVE

**BANC  
D'ENTRÉE**

VUES DE DESSUS,  
FACE ET DROITE  
(SECONDAIRE)

notes:

ÉCHELLE - 1:5

PAGE 1 DE 3

DESSINÉ PAR:  
mm

14/10/2025



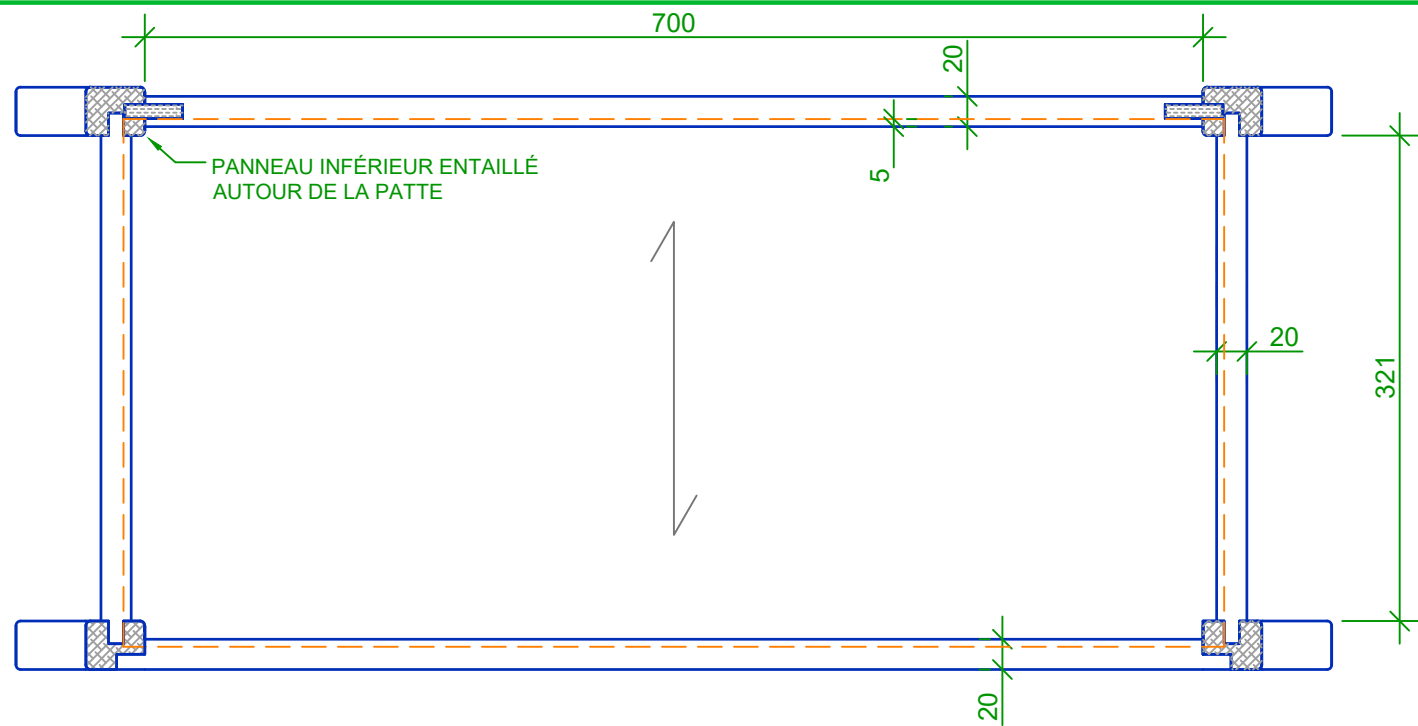

**COUPE C-C**

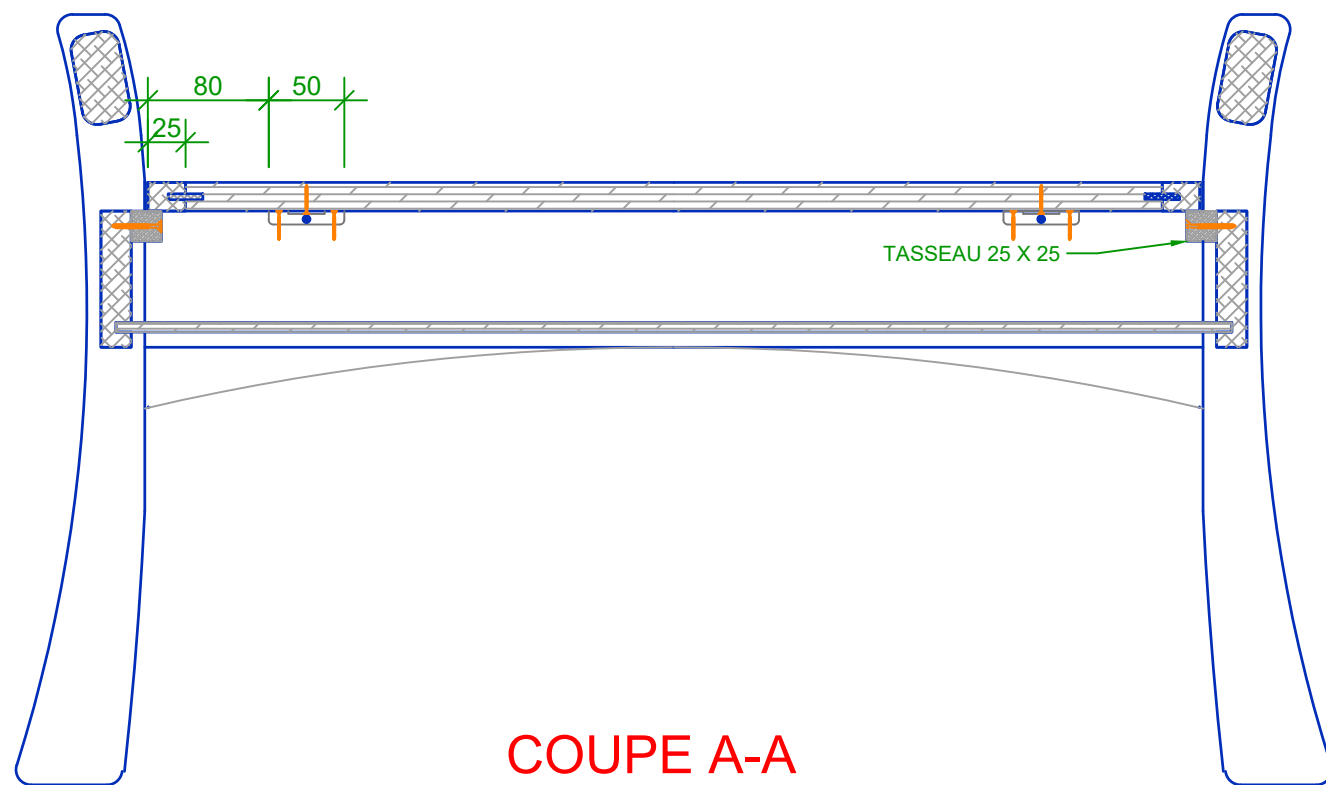

**COUPE A-A**

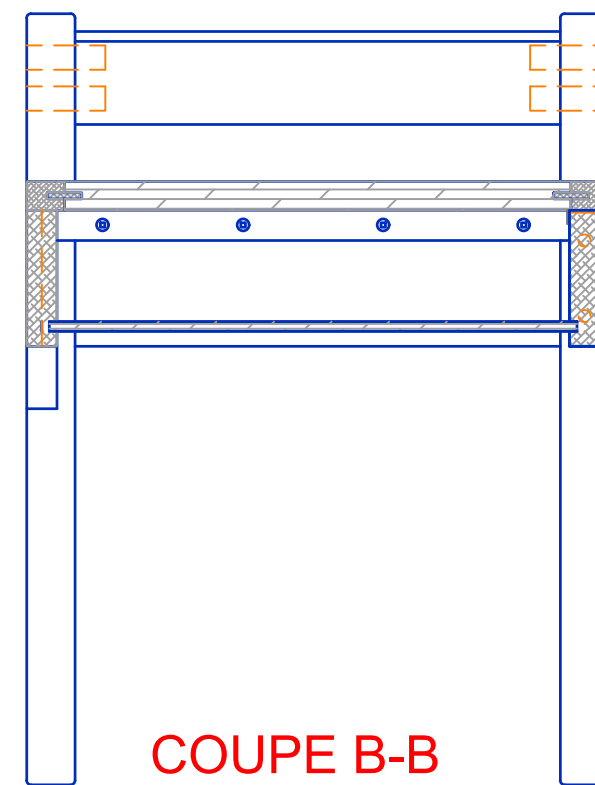

**COUPE B-B**



NUMÉRATIE



LECTURE

OCMT 2026  
ÉBÉNISTERIE  
(MÉTIER 24)  
PROJET  
D'ÉPREUVE

**BANC  
D'ENTRÉE**

**COUPES  
(SECONDAIRE)**

notes:

ÉCHELLE - 1:5

PAGE 2 DE 3

DESSINÉ PAR:  
mm

14/10/2025

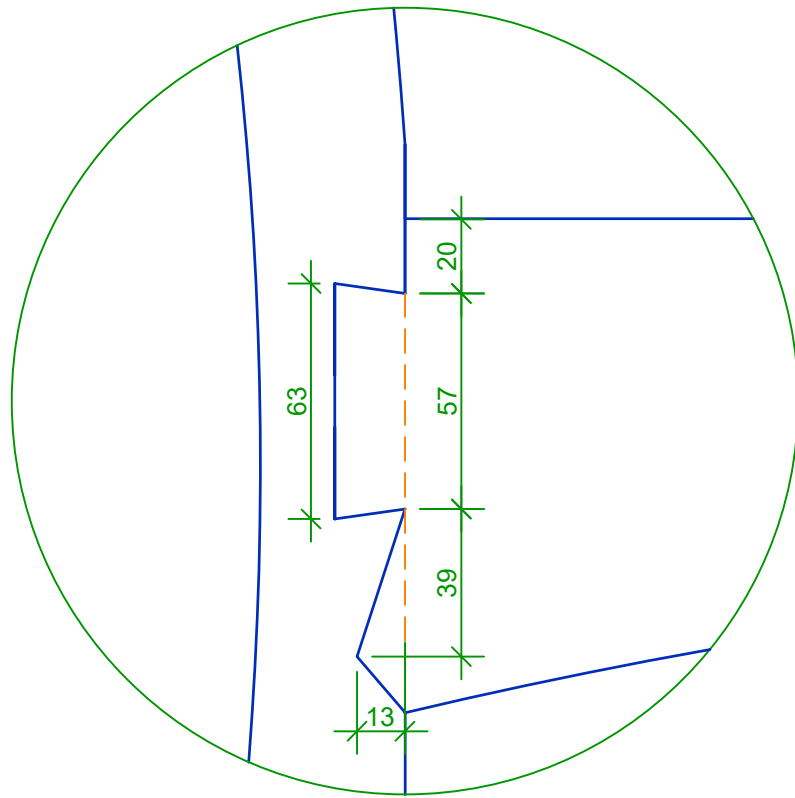

DÉTAIL QUEUE D'ARONDE AVEC COUPE BIAISE - ÉCHELLE 1:2

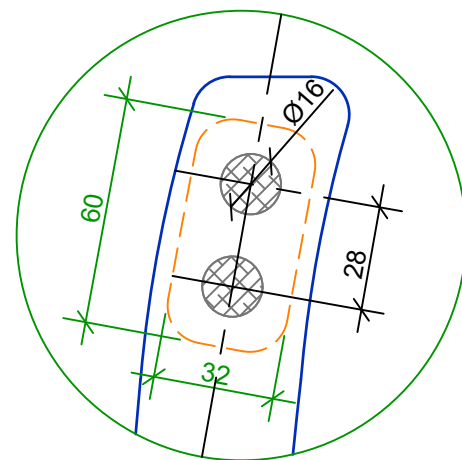

ASSEMBLAGE DE LA TRAVERSE SUPÉRIEURE - ÉCHELLE 1:2

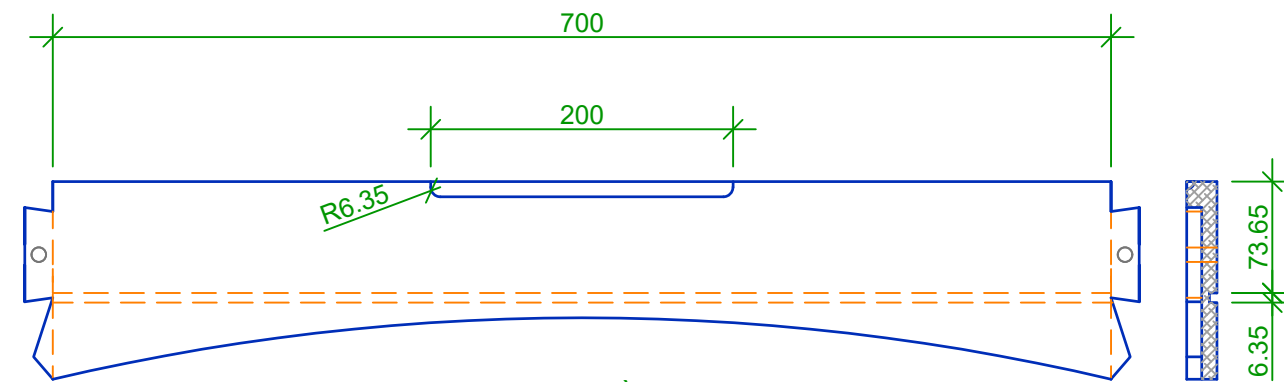

TRAVERSE AVANT À QUEUES D'ARONDE ET COUPES BIAISES

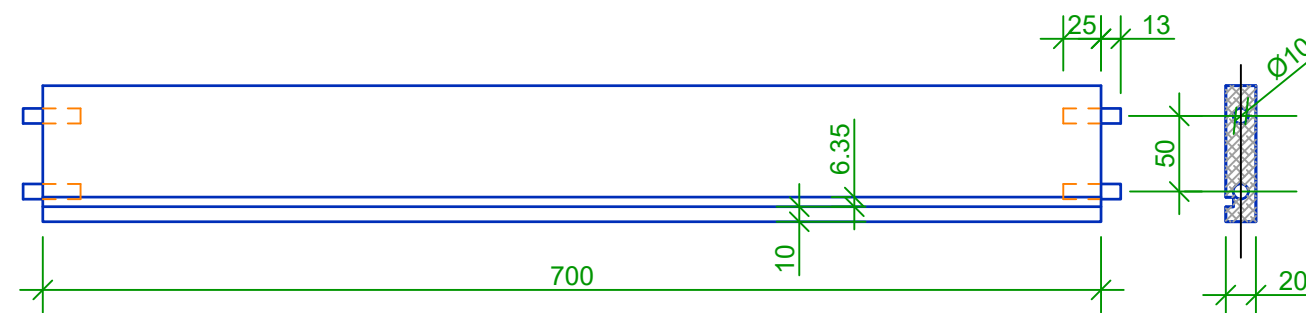

TRAVERSE ARRIÈRE

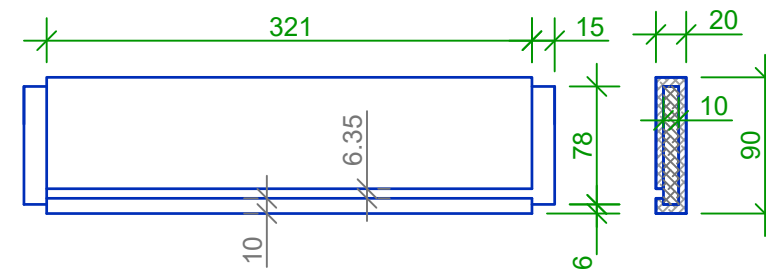

TRAVERSE DE CÔTÉ



NUMÉRATIE



LECTURE

OCMT 2026  
ÉBÉNISTERIE  
(MÉTIER 24)  
PROJET  
D'ÉPREUVE

**BANC  
D'ENTRÉE**

DÉTAILS  
D'ASSEMBLAGES  
(SECONDAIRE)

notes:

ÉCHELLE - 1:5  
OU TEL QUE MONTRÉ

PAGE 3 DE 3

DESSINÉ PAR:  
mm

14/10/2025