



4

3

2

1

ITEM	QTY / QTÉ	T / ÉP.	W / LARGEUR	L / LONGUEUR
A	2	6.35	245	256
B	1	9.53	100	200
C	1	9.53	100	150
D	1	6.35	170	193
E	1	6.35	69	69
F	1	9.53	100	150
G	1	9.53	62	200
H	1	6.35	65	68
J	1	9.53	94	200
K	2	9.53	100	100
L	1	9.53	137	175
M	2	6.35	29	65
N	1	9.53	119	175
P	3	6.35	50	125

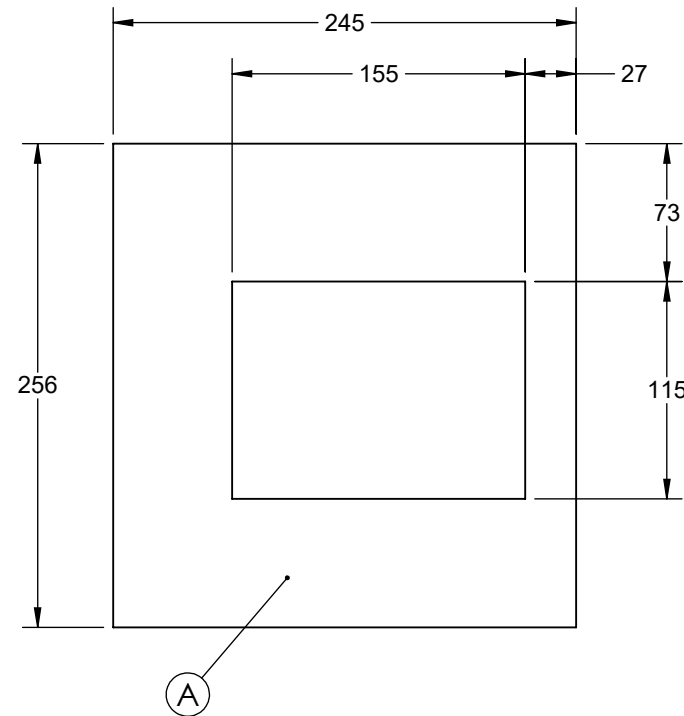

BEVEL / CHANFREIN

C

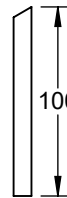

144

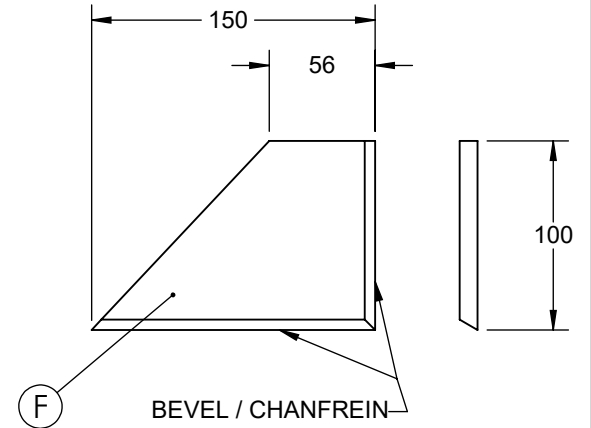
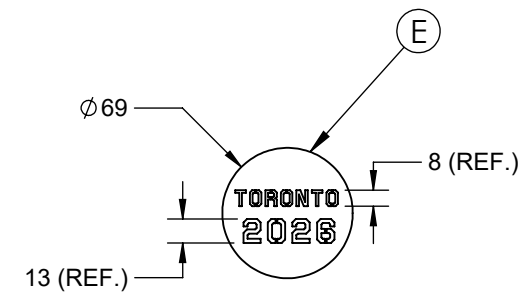

BEVEL / CHANFREIN

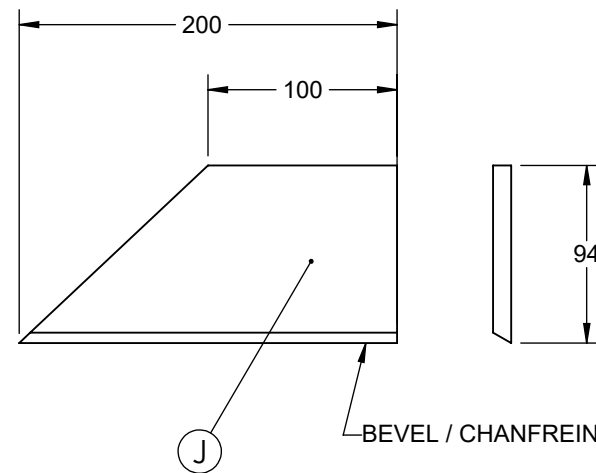
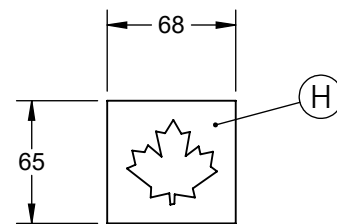

BEVEL / CHANFREIN

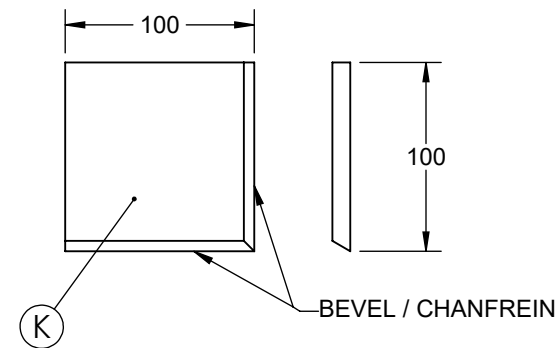

BEVEL / CHANFREIN

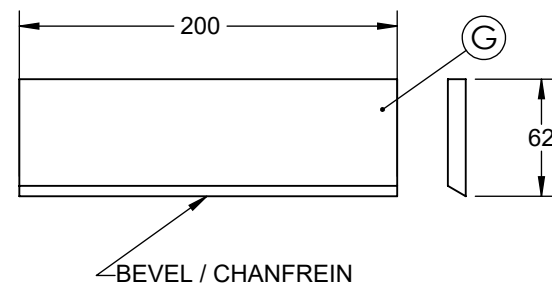

BEVEL / CHANFREIN

PREPARED GROOVE DIMENSIONS /  
DIMENSIONS DES RAINURES PRÉPARÉES

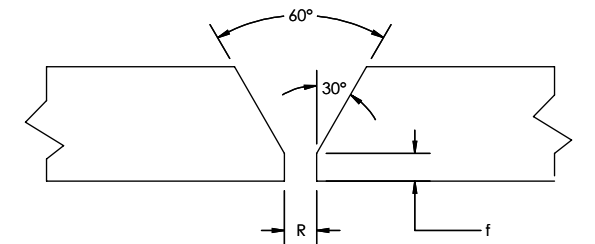

\* = ALL BEVEL AND VEE PREPARATIONS AS FOLLOWS:  
\* = PRÉPARER TOUTES LES SOUDURES EN V ET EN  
BISEAU COMME CECI :

R and f are prepared to the preference of the competitor.  
The dimension for the plates shown is to a feathered edge and  
any root gap must be accommodated in overall fitting dimensions.

R et f sont préparés selon les préférences du concurrent ou de la  
concurrente. Les dimensions des plaques présentées tiennent  
compte d'un rebord aminci et tout espacement des racines doit  
être pris en compte dans l'ensemble des dimensions  
d'assemblage.

ALL DIMENSIONS IN MILLIMETERS/TOUTES LES DIMENSIONS SONT EN MILLIMÈTRES



TITLE / TITRE:		SHEET # / NO. DE PAGE:		SIZE / TAILLE:	
SKILLS CANADA NATIONAL COMPETITION SECONDARY - DAY 2 COMPÉTITION NATIONALE DE COMPÉTENCES CANADA SECONDAIRE – JOUR 2		2 OF 2		B	
DWG. NO. / NO DESSIN:	REV.:	SCALE / ÉCHELLE:	DRAWN BY / DESSINÉ PAR:		
SCNC26-S2	1	1:4	J. HYDE		
DATE:			2026-01-15		

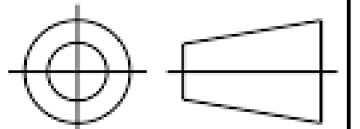

4

3

2

1